

LBX-522

Laser Diode

Optical characteristics *

Emission wavelength	522 nm (± 2 nm)	
Linewidth	≤ 2 nm	
Output power	Free space	Fiber coupled
	70 mW 100 mW	50 mW 70 mW
Control mode(s)	Automatic Power Control (APC) Automatic Current Control (ACC)	
Power stability over 8 hours and within $\pm 3k$	$\pm 0.5\%$	
Power adjustment range	0 - 100%	
Optical noise %RMS, 10Hz - 2 MHz bandwidth	$\leq 0.2\%$	

— Transverse singlemode free-space beam

Beam waist diameter (typ) at $1/e^2$, 50mm from output aperture	0.8 mm
Beam divergence at $1/e^2$, full angle, in far field	≤ 1 mrad
Beam quality factor (M^2)	≤ 1.25
Beam circularity , in far field	$\geq 90\%$
Polarization extinction ratio (typ)	100:1
Polarization state	linear, vertical at $\pm 5^\circ$

— Modulation functions

Digital Modulation

Max modulation frequency	150 MHz
Rise/fall time, 10%-90%	≤ 2 ns

Analog Modulation

Bandwidth 3dB cut-off frequency, ACC mode	≥ 3 MHz
Rise/fall time, 10%-90%	≤ 150 ns

Fiber coupling option

	SM and PM Fiber	MM Fiber (50 μ m, 0.22 NA)
Coupling Efficiency	$\geq 70\%$	$\geq 80\%$
Polarization Ratio (PMF only)	100 : 1	n/a
Fiber Output Connector	FC-APC FC/PC, FCP8 on demand	FC-APC
Power stability over 8 hours and within $\pm 3k$	$\pm 2\%$	$\pm 2\%$
Fiber length	2.0 m	2.0 m

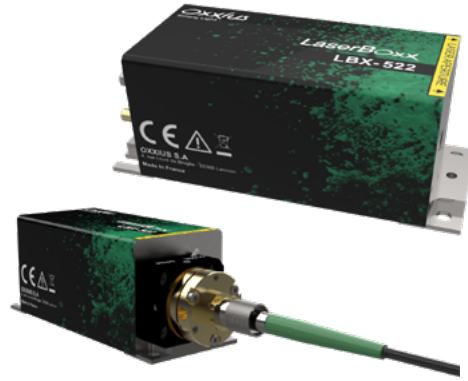

Mechanical drawings

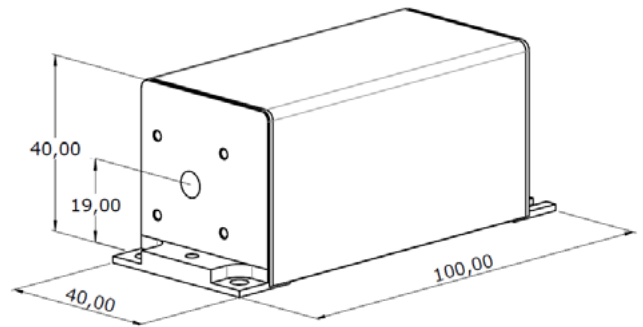

— Plug and Play version provided with :

- ControlBoxx
- Power supply

Options

- Electro-mechanical shutter
- Heat sink
- Clean-up filter

General specifications

	Plug and Play version	OEM version
Compliance	CE FDA 21 CFR 1040.10/1040.11	FDA 21 CFR 1040.10 / 1040.11
Operating temperature	10 - 38°C ambient air with optional heat sink	10 - 50°C baseplate
Power consumption	≤ 25 W	≤ 10 W
Storage temperature	0 to 60°C	
Supply voltage	100 to 240 VAC external power supply	5 to 12 VDC
Warm-up time	≤ 2 minutes	
Interfaces	USB, RS-232, dedicated electronic interface	

Warranty : 12 months from shipment date

*Specifications at nominal power



CONTACT US

Oxxius S.A
4 rue Louis de Broglie
F-22300 Lannion, France

Phone : +33 296 48 70 28
sales@oxxius.com
www.oxxius.com