

830nm 1W Fiber Coupled Diode Laser

RPK830-02-1.000W-05014-ST (Standard Product)

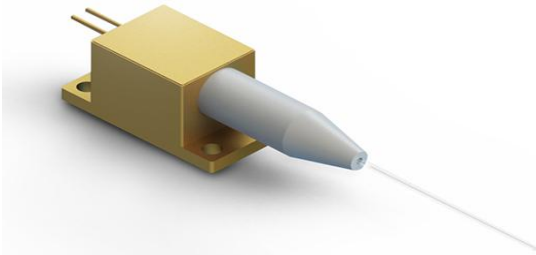

Features:

- ◆ 830nm wavelength
- ◆ 1W output power
- ◆ 50µm fiber core diameter
- ◆ 0.14 NA

Applications:

- ◆ Printing application
- ◆ Medical use
- ◆ Scientific research

Specifications (25°C)		Symbol	Unit	RPK830-02-1.000W-05014-ST		
				Minimum	Typical	Maximum
Optical Data ⁽¹⁾	CW Output Power	P _O	W	1	-	-
	Center Wavelength ⁽²⁾	λ _c	nm	830±10		
	Spectral Width(FWHM)	Δλ	nm	-	6	-
	Wavelength Shift with Temperature	Δλ/ΔT	nm/°C	-	0.3	-
Electrical Data	Electrical-to-Optical Efficiency	PE	%	-	40	-
	Threshold Current	I _{th}	A	-	0.2	-
	Operating Current	I _{op}	A	-	-	1.5
	Operating Voltage	V _{op}	V	-	-	2
	Slope Efficiency	η	W/A	-	0.9	-
Fiber Data	Core Diameter	D _{core}	µm	-	50	-
	Cladding Diameter	D _{clad}	µm	-	125	-
	Numeric Aperture	NA	-	-	0.14	-
	Fiber Length	L _f	m	-	0.5	-
	Fiber Loose Tubing Diameter	-	mm	0.9		
	Minimum Bending Radius	-	mm	50	-	-
	Fiber Termination	-	-	ST		
Others	ESD	V _{esd}	V	-	-	500
	Storage Temperature ⁽²⁾	T _{st}	°C	-20	-	70
	Lead Soldering Temp	T _{ls}	°C	-	-	260
	Lead Soldering Time	t	sec	-	-	10
	Operating Case Temperature ⁽³⁾	T _{op}	°C	15	-	35
	Relative Humidity	RH	%	15	-	75

(1) Data measured under operation output at 1W@25°C.

(2) A non-condensing environment is required for operation and storage.

(3) Operating temperature defined by the package case. Acceptable operating range is 15°C~35°C, but performance may vary.

830nm 1W Fiber Coupled Diode Laser RPK830-02-1.000W-05014-ST (Standard Product)

Package Dimensions (mm)

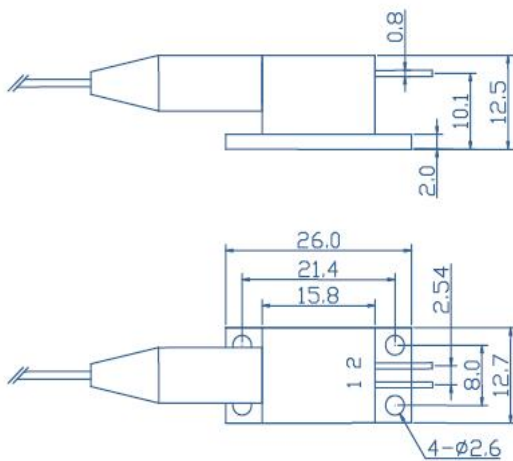

Pin	Function
1	LD (+)
2	LD (-)

OPERATING NOTES

- ◆ Avoid eye and skin exposure to direct radiation during operation.
- ◆ ESD precautions must be taken during storage, transportation and operation.
- ◆ Short-circuit is required between pins during storage and transportation.
- ◆ Please connect pins to wires by solder instead of using socket when operation current is higher than 6A. Soldering point should be close to the middle of the pins. Soldering temperature should be lower than 260°C and time shorter than 10 second.
- ◆ Make sure the fiber output end is properly cleaned before operation of laser. Follow safety protocols to avoid injury when handling and cutting the fiber.
- ◆ Use constant current power supply to avoid surge current during operation.
- ◆ Laser diode must be used according to the specifications.
- ◆ Laser diode must work with good cooling.
- ◆ Operation temperature ranges from 15°C to 35°C .
- ◆ Storage temperature ranges from -20°C to +70°C .



Declaration: information and specifications contained herein are deemed to be reliable and accurate. BWT Beijing reserves the right to change, alter or