

940nm 10W Fiber Coupled Diode Laser

RPK940-B2-10.00W-10522-FF

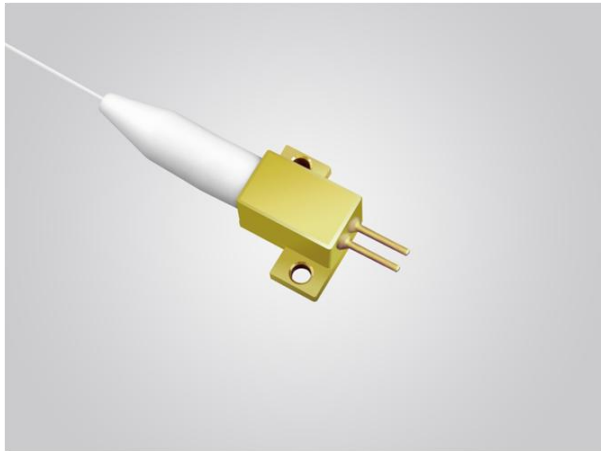

Features:

- ◆ 940nm wavelength
- ◆ 10W output power
- ◆ 105µm fiber core diameter
- ◆ 0.22F.F.
- ◆ 1040nm-1200nm feedback protection

Applications:

- ◆ Laser pumping
- ◆ Medical Use
- ◆ Material Processing

Specifications(25°C)		Symbol	Unit	RPK940-B2-10.00W-10522-FF		
				Minimum	Typical	Maximum
Parameter ⁽¹⁾	CW Output Power	P _O	W	11	-	-
	Threshold current	I _{th}	A	-	1	-
	Operating current	I _{op}	A	-	12	14
	Operating voltage	V _{op}	V	-	-	2
	Reverse Voltage	V _{re}	V	-	2.5	-
	Slope Efficiency	η	W/A	-	1	-
	Electrical-to-Optical Efficiency	PE	%	-	48	-
	Center wavelength	λ _c	nm	930	-	950
	Spectral width(FWHM)	δλ	nm	-	6	-
	Back reflection wavelength Range	λ	nm	1040	-	1200
	Back reflection isolation	-	dB	-	30	-
	Wavelength Shift with Temperature	-	nm/°C	-	0.3	-
	Light within 0.15NA	NA	-	-	95	-
	Life Time	MTTF	hrs	-	100000	-
Fiber Date	Buffer diameter	D _{buf}	µm	-	250	-
	Cladding diameter	D _{clad}	µm	-	125	-
	Core diameter	D _{core}	µm	-	105	-
	Numeric aperture	NA	-	-	0.22	-
	Fiber length ⁽²⁾	l _f	m	-	1	-
	Fiber Bend Radius	-	mm	37.5	-	-
Others	ESD	V _{esd}	V	-	-	500
	Storage temperature	T _{stg}	°C	-20	-	70
	Lead Soldering Temp	T _{ls}	°C	-	-	260
	Lead Soldering Time	t	sec	-	-	10
	Operating case temperature	T _{op}	°C	15	-	35
	Relative Humidity	RH	%	15	-	75

(1) Data measured under operation output at 11W.

(2) Other fibers available upon request.

940nm 11W Fiber Coupled Diode Laser

RPK940-B2-10.00W-10522-FF

Characteristics

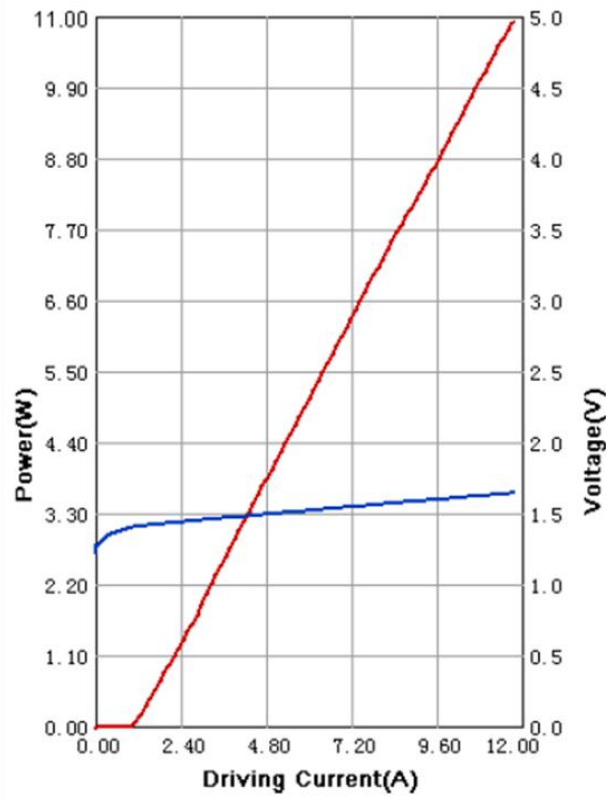

940nm 11W Fiber Coupled Diode Laser

RPK940-B2-10.00W-10522-FF

Package Dimensions (mm)

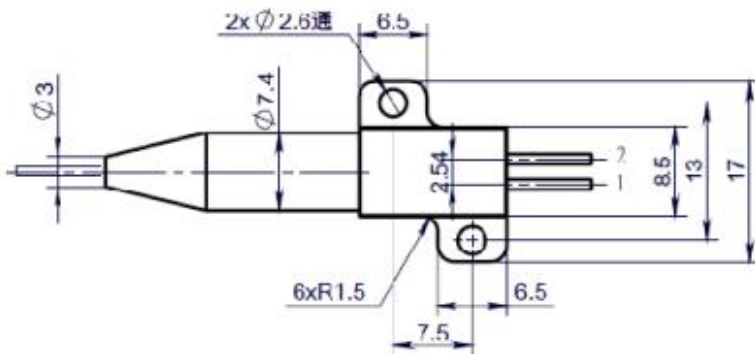
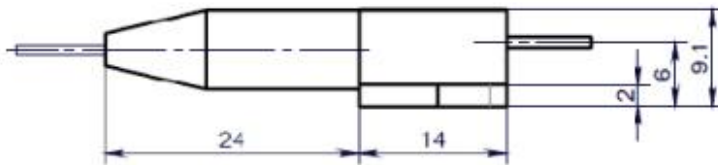

Pins	Function
1	LD (+)
2	LD (-)

OPERATING NOTES

- ◆ Avoid eye exposure to direct or scattered radiation.
- ◆ ESD precautions must be taken.
- ◆ Please connect pins to wires by solder instead of using socket when operation current is higher than 6A.
- ◆ Soldering point should be close to the root of the pins. Soldering temperature should be lower than 260°C and time shorter than 10 second.
- ◆ Use constant current power supply. Avoid surge current.
- ◆ Laser diode must be used according to the specifications.
- ◆ Laser diode must work with good cooling.
- ◆ A minimum bend radius should be 300 times greater than the fiber cladding diameter, dynamic bend radius should be 400 times greater than the fiber cladding diameter.
- ◆ Operation temperature is 15°C ~ 35°C.
- ◆ Storage: -20°C ~ +70°C, all pins short-circuit.

