

976nm 100W Wavelength-Stabilized High Brightness Diode Laser
RPK976S-B2-9.000W-10522-NA (Customized Product)

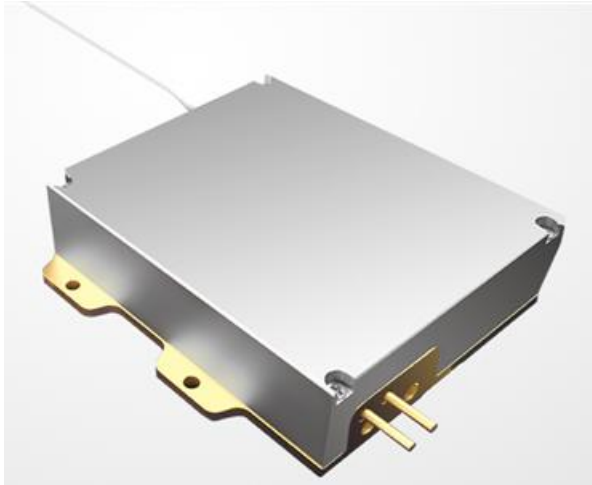

Features:

- ◆ 976nm wavelength
- ◆ 100W output power
- ◆ 105 μ m fiber core diameter
- ◆ 0.22N.A.
- ◆ 1020nm-1200nm feedback protection

Applications:

- ◆ Fiber laser pumping

High Power Diode Laser Modules are manufactured by adopting specialized fiber-coupling techniques, resulting in volume products with a high efficiency, stability and superior beam quality. The products are achieved by transforming the asymmetric radiation from the laser diode chip into an output fiber with small core diameter by using special micro optics. Inspecting and burn-in procedures in every aspect come to a result to guarantee each product with the reliability, stability and long lifetime.

Our research staffs are constantly improving and innovating the processing technology in the producing process, based on the professional knowledge and experience accumulated in long-terms. We are also continuously developing new products to meet customers' specific needs.

High quality products with reasonable price is our always goal.

976nm 100W Wavelength-Stabilized High Brightness Diode Laser
RPK976S-B2-9.000W-10522-NA (Customized Product)

Specifications(25°C)		Symbol	Unit	RPK976S-B2-9.000W-10522-NA		
				Minimum	Typical	Maximum
Optical Data ⁽¹⁾⁽²⁾	CW-Output Power	P_o	W	100	-	
	Center Wavelength	λ_c	nm	975.5	976	976.5
	Spectral Width (FWHM)	$\Delta\lambda$	nm	-	-	0.7
	Wavelength Shift with Temperature	$\Delta\lambda/\Delta T$	nm/°C	-	-0.02	-
	Wavelength locked Range	$\Delta\lambda_{op}$	Å	(lop-2Å)-lop		
Electrical Data	Operating Current	I_{op}	A	-	13	14.5
	Threshold Current	I_{th}	A	-	0.9	-
	Electrical-to-Optical Efficiency	η	%	-	47	-
	Slope Efficiency	η_D	W/A	-	8.3	-
	Operating Voltage	V_{op}	V	-	16.5	17.5
Fiber Data	Core diameter	D_{core}	µm	-	105	-
	Cladding diameter	D_{clad}	um	-	125	-
	Numerical Aperture	N.A.	-	-	0.22	-
	Total Fiber Length	-	m	-	2.0	-
	Fiber Loose Tubing Diameter	-	µm	-	900	-
	Minimum Static Bending Radius	-	mm	80.0	-	-
	Connector	-	-	-	None	-
Feedback Isolation	Wavelength Range	λ	nm	1020	-	1200
	Isolation	-	dB	-	30	-
Others	Operating Case Temperature	T_{op}	°C		25	
	Storage Temperature (Non-operating)	T_{st}	°C	-20	-	+70
	ESD	-	V	-	-	500
	Lead Soldering Temp	-	° C	-	-	260
	Lead Soldering Time	-	sec	-	-	10
	Relative Humidity	-	%	15	-	75

- (1) Data measured under operation output at 100W @25°C Case Temperature
(2) Operating temperature defined by the package housing. Acceptable operating range is 20 - 30C, but performance may vary
(3) Wavelength stabilized to >90% power in band of 974.5nm to 977.5 nm.

976nm 100W Wavelength-Stabilized High Brightness Diode Laser
RPK976S-B2-9.000W-10522-NA (Customized Product)

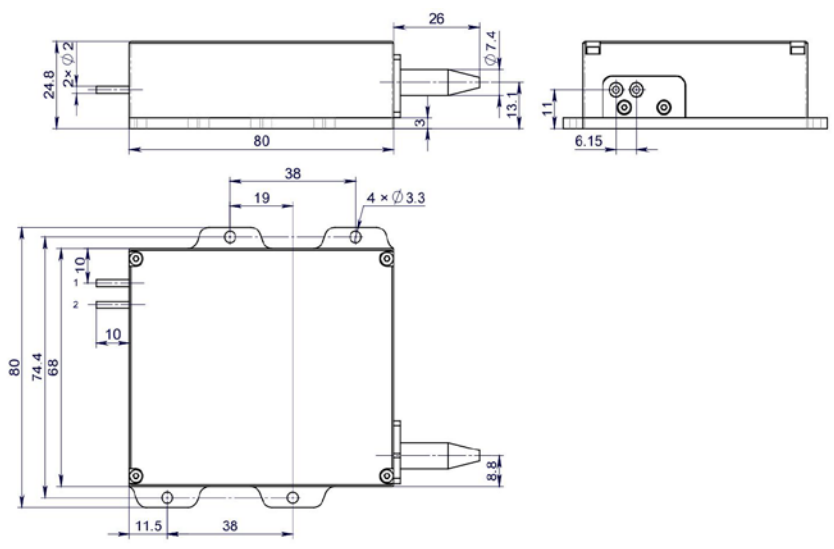
Package Dimensions (mm)							
 <p>Technical drawings of the laser package showing side, top, and front views with dimensions in millimeters. Key dimensions include: length 80mm, width 80mm, and various mounting and fiber-related dimensions.</p>	<table border="1" style="width: 100%; border-collapse: collapse; text-align: center;"> <thead> <tr style="background-color: #cccccc;"> <th style="padding: 5px;">Pin</th> <th style="padding: 5px;">Function</th> </tr> </thead> <tbody> <tr> <td style="padding: 5px;">1</td> <td style="padding: 5px;">LD (+)</td> </tr> <tr> <td style="padding: 5px;">2</td> <td style="padding: 5px;">LD (-)</td> </tr> </tbody> </table>	Pin	Function	1	LD (+)	2	LD (-)
Pin	Function						
1	LD (+)						
2	LD (-)						

OPERATING NOTES

- ◆ ESD protection measures must be taken during storage, transportation and operation.
- ◆ Solder pins instead of using socket for electrical connections for modules with operating current higher than 6A. Soldering temperature should be lower than 260°C and soldering duration should be less than 10 seconds.
- ◆ Make sure the fiber output end is properly cleaned before operation of laser. Follow safety protocols to avoid injury when handling and cutting the fiber.
- ◆ Fiber bending radius should be bigger than 60mm to avoid leaking of laser light.
- ◆ Diode laser should be operated according to the specification. Over-drive the diode laser will reduce its lifetime.
- ◆ Avoid eye and skin exposure to direct radiation during operation.
- ◆ Use constant current power supply. Current surge may damage the laser.
- ◆ Diode laser must be operated under good cooling condition.

