

**976nm 180W Wavelength-Stabilized High Power Fiber Coupled Diode Laser**  
**RPK976S-N1-180.0W-20022-NA (Optional Product)**

---

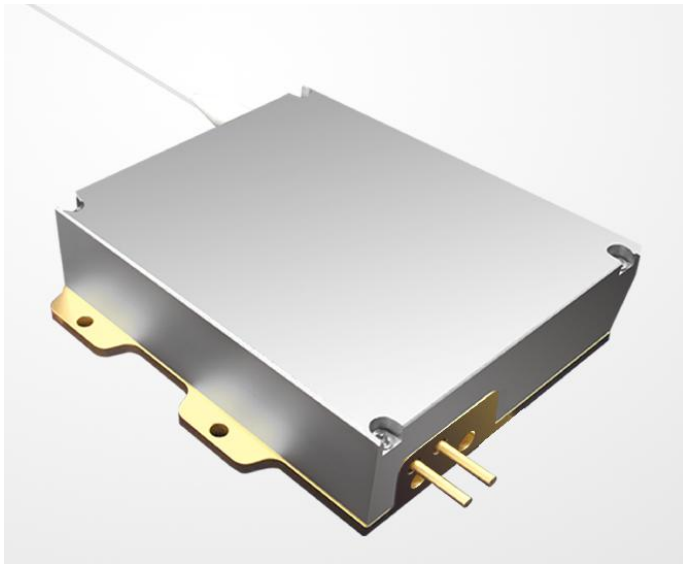

**Features:**

- ◆ 976nm wavelength
- ◆ 180W output power
- ◆ 200 $\mu$ m fiber core diameter
- ◆ 0.22N.A.
- ◆ 1040nm-1200nm feedback protection

**Applications:**

- ◆ Fiber laser pumping

High Power Diode Laser Modules are manufactured by adopting specialized fiber-coupling techniques, resulting in volume products with a high efficiency, stability and superior beam quality. The products are achieved by transforming the asymmetric radiation from the laser diode chip into an output fiber with small core diameter by using special micro optics. Inspecting and burn-in procedures in every aspect come to a result to guarantee each product with the reliability, stability and long lifetime.

Our research staffs are constantly improving and innovating the processing technology in the producing process, based on the professional knowledge and experience accumulated in long-terms. We are also continuously developing new products to meet customers' specific needs.

High quality products with reasonable price is our always goal.

---

**976nm 180W Wavelength-Stabilized High Power Fiber Coupled Diode Laser**  
**RPK976S-N1-180.0W-20022-NA (Optional Product)**

Specifications(25°C)	Symbol	Unit	RPK976-180.0W-20022-NA			
			Minimum	Typical	Maximum	
Optical Data <sup>(1)</sup>	CW-Output Power	P <sub>o</sub>	W	180	-	-
	Center Wavelength	λ <sub>c</sub>	nm	976±1		
	Spectral Width (FWHM)	Δλ	nm	< 1		
	Wavelength Locked range	-	Å	(I <sub>op</sub> -2) ~ I <sub>op</sub>		
	Wavelength Shift with Temperature	Δλ/ΔT	nm/°C	-	0.02	-
	Wavelength Shift with Current	Δλ/ΔI	nm/A	-	0.03	-
Electrical Data	Electrical-to-Optical Efficiency	PE	%	-	45	-
	Operating Current	I <sub>op</sub>	A	-	13	14
	Threshold Current	I <sub>th</sub>	A	-	0.9	-
	Operating Voltage	V <sub>op</sub>	V	-	31.5	35
	Slope Efficiency	η	W/A	-	13	-
Fiber Data <sup>(2)</sup>	Core diameter	D <sub>core</sub>	μm	-	200	-
	Cladding diameter	D <sub>clad</sub>	um	-	220	-
	Buffer diameter	D <sub>buf</sub>	um	-	320	-
	Numerical Aperture	N.A.	-	-	0.22	-
	Total Fiber Length	L <sub>f</sub>	m	1.9	2	-
	Fiber Loose Tubing Diameter/Length	-	μm	0.9mmPTFE/180cm		
	Minimum Bending Radius	-	mm	88	-	-
Feedback Isolation	Fiber termination	-	-	-	FPT	-
	Wavelength Range <sup>(3)</sup>	λ	nm	1040~1200		
Others	Isolation	-	dB	-	30	-
	ESD	V <sub>esd</sub>	V	-	-	500
	Storage Temperature (Non-operating) <sup>(4)</sup>	T <sub>st</sub>	°C	-20	-	70
	Lead Soldering Temp	T <sub>is</sub>	°C	-	-	260
	Lead Soldering Time	t	sec	-	-	10
	Operating Case Temperature <sup>(5)</sup>	T <sub>op</sub>	°C	25	-	30
Relative Humidity	RH	%	15	-	75	

(1) Data measured under operation output at 180W.

(2) Other fiber type customized according to customers requirements.

(3) Other feedback isolation customized according to customers requirements.

(4) A non-condensing environment is required for operation and storage conditions are from -20 to +70 °C with relative humidity between 15 to 75 %.

(5) Operating temperature defined by the package housing. Acceptable operating range is 25 - 30C, but performance may vary.

**976nm 180W Wavelength-Stabilized High Power Fiber Coupled Diode Laser**  
**RPK976S-N1-180.0W-20022-NA (Optional Product)**

---

**Characteristics**

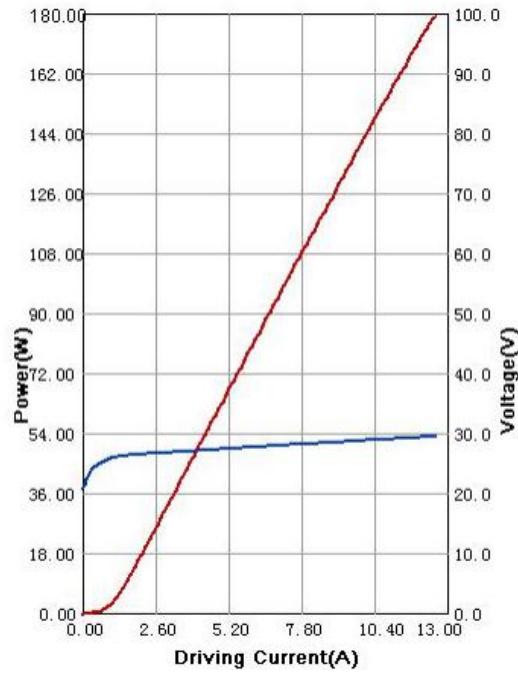

**Spectrum**

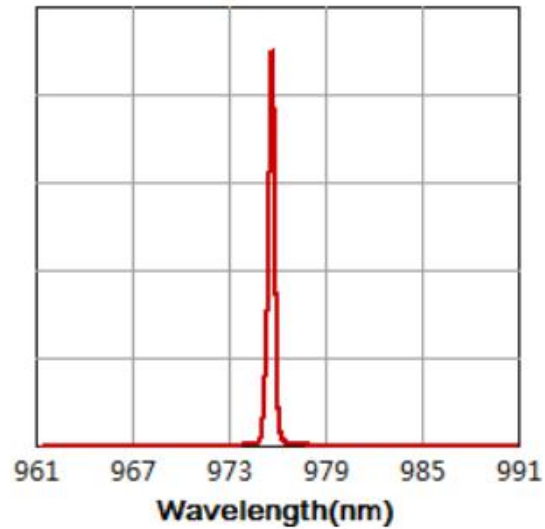

**976nm 180W Wavelength-Stabilized High Power Fiber Coupled Diode Laser**  
**RPK976S-N1-180.0W-20022-NA (Optional Product)**

**Package Dimensions (mm)**

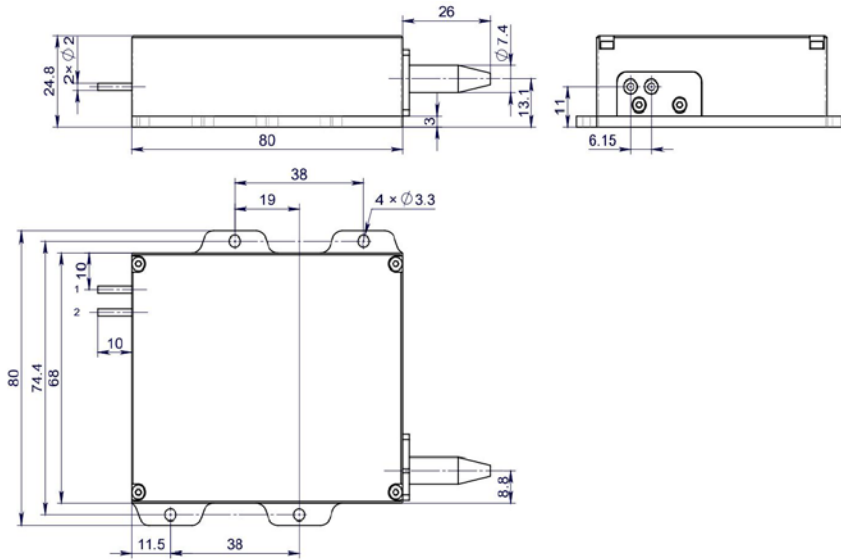

Pins	Function
1	LD (+)
2	LD (-)

\*: Optional functions.

**OPERATING NOTES**

- ◆ Avoid eye exposure to direct or scattered radiation.
- ◆ ESD precautions must be taken.
- ◆ Please connect pins to wires by solder instead of using socket when operation current is higher than 6A.
- ◆ Soldering point should be close to the root of the pins. Soldering temperature should be lower than 260°C and time shorter than 10 second.
- ◆ Use constant current power supply. Avoid surge current.
- ◆ Laser diode must be used according to the specifications.
- ◆ Laser diode must work with good cooling.
- ◆ Operation temperature is 25°C~ 30°C.
- ◆ Storage: -20°C~ +70°C, all pins short-circuit.

