

1310nm LASER

REP1310-ADF-B

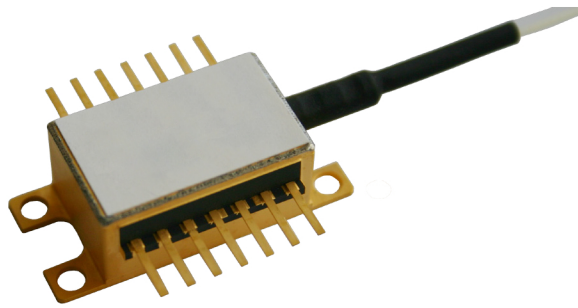

www.rpmclasers.com



ADVANCED COMMUNICATIONS

RPMC Lasers REP1310-ADF-B laser diode is especially designed for telecoms applications such as long reach ana-log transmission and CATV. This cost effective laser features a highly linear output and excellent SMSR performance.

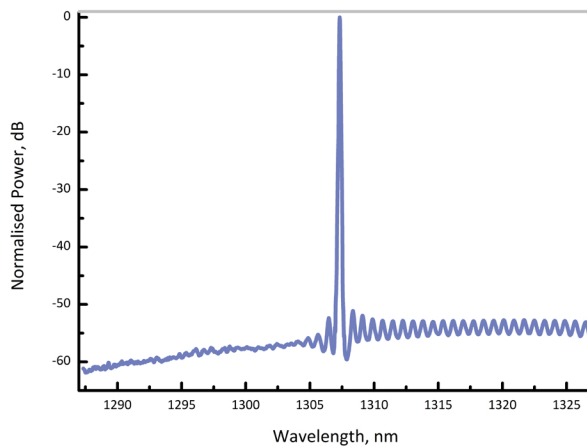

Optical Spectrum at 25°C

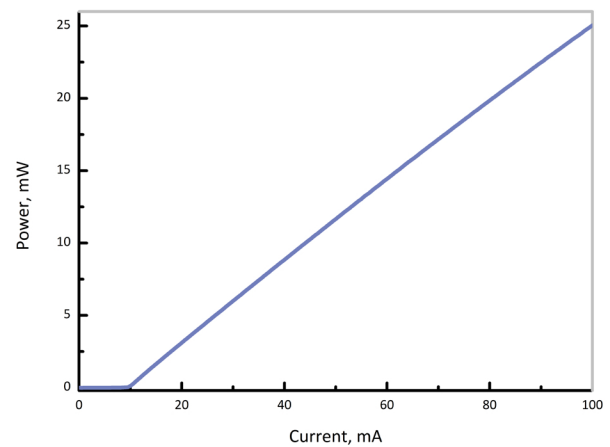

Output power as a function of bias current

ELECTRO-OPTICAL CHARACTERISTICS* ($T_{SUB} = 25^{\circ} C$)

PARAMETER	SYMBOL	MIN	TYP	MAX	UNIT
Available Wavelength Range	λ	-	1310	-	nm
Wavelength Tolerance	λ_{spec}	$\lambda - 5$	λ	$\lambda + 5$	nm
Side Mode Supression Ratio	SMSR	35	-	-	dB
Threshold Current	I_{th}	-	9	20	mA
Slope Efficiency	SE	0.14	0.28	-	mW/mA
Output Power in fiber	P_f	10	20	-	mW
Relative Intensity Noise (40 - 1000 MHz)	RIN	-	-155	-	dB/Hz
Temperature Tuning Coefficient	T_{λ}	-	0.1	-	nm/°C
Thermistor Resistance	R_T	9.5	10	10.5	k Ω
Thermistor Temp. Coefficient	C	-	-4.4	-	%/°C

ABSOLUTE MAXIMUM RATINGS

PARAMETER	SYMBOL	MIN	MAX	UNIT
Forward Current	I_f	-	100	mA
Forward Voltage	V_f	-	2	V
TEC Current	I_{TEC}	-	1.5	A
Reverse Voltage LD	V_r	-	2	V
Reverse Voltage mPD	V_{rev}	-	20	V
Case Temperature*	T_{Case}	-20	65	°C
Storage Temperature	$T_{storage}$	-40	85	°C

*For $T_{sub} < 25^{\circ}C$, Max Case Temperature should be derated to $T_{Case,Max} = T_{sub} + 40^{\circ}C$

PACKAGING

The REP1310-ADF-B product series is offered in a 14-pin Butterfly package. The standard package pinout is shown below.

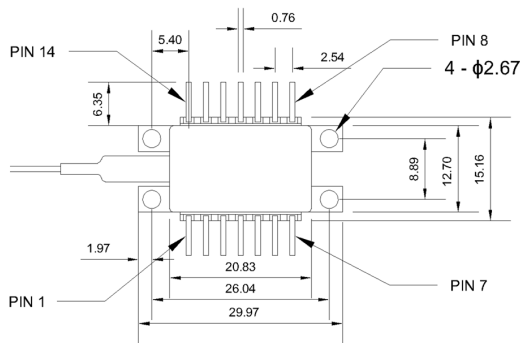

14-pin butterfly schematic

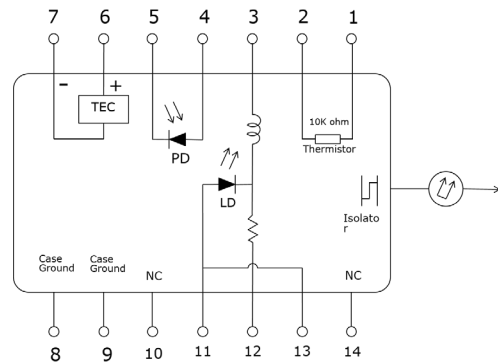

Standard "Pinout 10" option

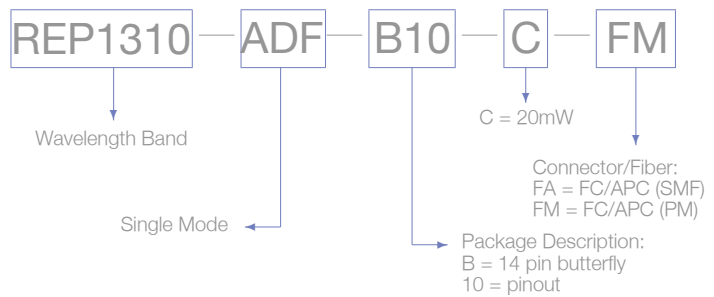

Laser Safety

This is a Class 3R Laser Product as defined by International Standard IEC 60825-1, Edition 3. Invisible Laser radiation is emitted from the end of the fiber or connector. Avoid direct eye exposure to the beam. Laser safety labels are not attached to the module due to space limitations but instead are affixed to the outside of the shipping carton.