

1742nm DX1 - Sensing

REP1742-DM-DX1

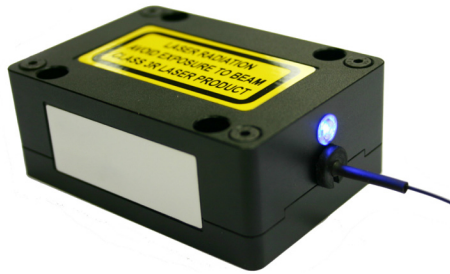

www.rpmclasers.com



ACCURATE HCI MONITORING

A new product addition designed for sensitive detection of HCI, the REP1742-DM-DX1, available in the 1735-1770nm range, combines RPMC's Discrete Mode (DM) technology with an integrated current driver and TEC controller to create a complete sensing solution featuring excellent SMSR and mode-hop free tuning.

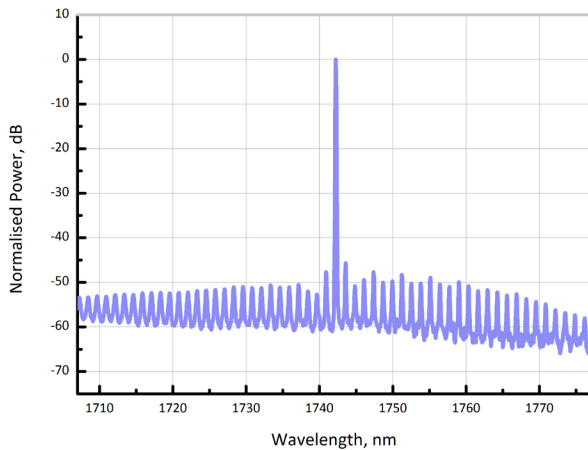

Optical Spectrum at 25°C

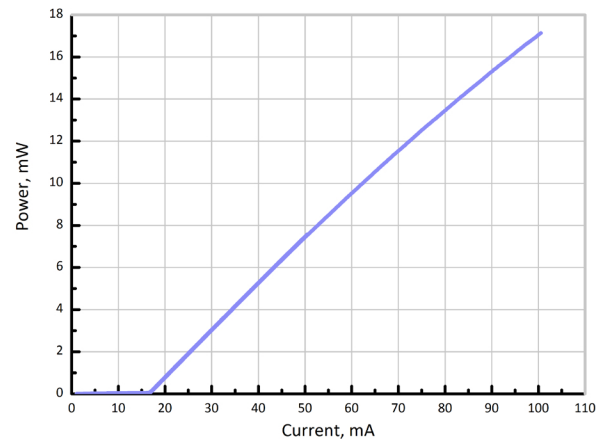

Output power (ex-facet) as a function of bias current

ELECTRO-OPTICAL CHARACTERISTICS* ($T_{SUB} = 25^{\circ} C$)

PARAMETER	SYMBOL	MIN	TYP	MAX	UNIT
Centre Wavelength Range	λ	1735	1742	1770	nm
Wavelength specification	λ_{spec}	$\lambda - 1$	λ	$\lambda + 1$	nm
Side Mode Supression Ratio	SMSR	30	40	-	dB
Threshold Current	I_{th}	-	15	20	mA
Output Power in fiber	P_f	5	8	10	mW
Optical linewidth	Δf	-	-	2	MHz
Temperature Tuning Coefficient	T_{λ}	0.07	0.1	0.14	nm/°C
Current Tuning Coefficient	I_{λ}	8	14	20	pm/mA
Slope Efficiency	SE	-	0.06	-	mW/mA
Modulation bandwidth	f_{3dB}	DC	-	100	kHz
Wavelength stability (CW)	-	-	<10	-	pm

*CW bias unless otherwise stated

ABSOLUTE MAXIMUM RATINGS

PARAMETER	SYMBOL	MIN	TYP	MAX	UNIT
Supply voltage	V_s	4.5	5	5.5	V
LD bias current	I_f	-	70	120	mA
Bias voltage	V_f	-	0.7	1.2	V
TEC voltage	I_{TEC}	0.1	1.5	3	V
Submount Temperature*	T_{Case}	15	-	35	°C
Storage Temperature	$T_{storage}$	-40	-	85	°C
Fibre bend radius	r_{min}	30	-	-	mm

*For $T_{sub} < 25^{\circ}C$, Max Case Temperature should be derated to $T_{Case,Max} = T_{sub} + 40^{\circ}C$

PACKAGING

The REP1742-DM-DX1 product series is offered in propri-etary DX-1 module with integrated current driver and TEC controller - Inquire for other packaging options.

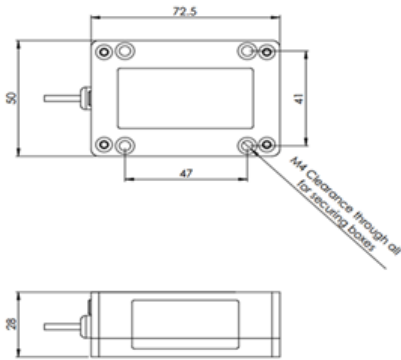

Schematic diagram of DX-1 module

PIN NO	NAME	DESCRIPTION
1	V_{CC}	5V rail voltage
2	V_{TEC}	Sets TEC temperature
3	Gnd	Ground
4	NC	-
5	NC	-
6	V_{bias}	Sets bias current

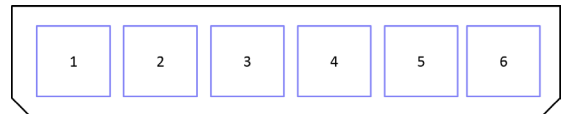

6-pin plug schematic (facing socket)

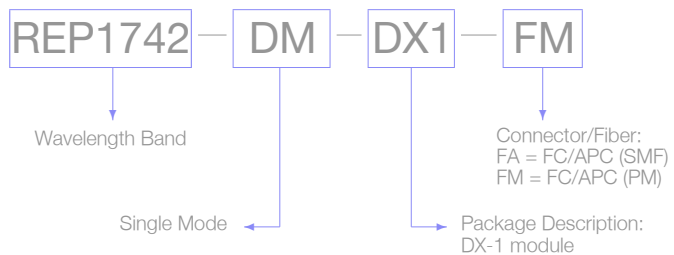

Laser Safety

This is a Class 3R Laser Product as defined by International Standard IEC 60825-1, Edition 2. Invisible Laser radiation is emitted from the end of the fiber or connector. Avoid direct eye exposure to the beam. Laser safety labels are not attached to the module due to space limitations but instead are affixed to the outside of the shipping carton.