



PART NUMBER 0450L-15A
 ITEM NAME 450 NM LASER (DIODE; PM FIBER)

PRODUCT DATASHEET



DESCRIPTION

450 nm laser diode module is an excellent choice for flow cytometry, fluorescence, and biomedical applications. Small footprint, stable power, low power consumption are only a few advantages of this laser. This particular version of 450 nm laser is fiber coupled to a PM (polarization-maintaining) fiber. By default, this type of laser is built with FC/PC connector, but other fiber terminations are available upon request. Details about non-standard connector and the fiber used with it should be discussed with the Integrated Optics sales team.

SPECIFICATIONS

Specifications updated: 9 July 2021

Parameter	Minimum Value	Typical Value	Maximum Value
Central Wavelength, nm	442	450	458
Longitudinal modes	-	Multiple	-
Spectral line width FWHM, nm	0.01	0.8	1
Output power, mW	-	35 ¹	50
Power stability, % (RMS, 8 hrs)	0.02	0.1 ²	0.5
Power stability, % (peak-to-peak, 8 hrs)	0.1	0.5 ³	1
Intensity noise, % (RMS, 20 Hz to 20 MHz)	0.05	0.25 ⁴	0.6
Transversal modes	-	TEM ₀₀	-
M ² effective	-	1.05	1.1
Polarization direction	-	Aligned within the slow axis of the PM fiber and the key position.	-
Polarization extinction ratio (from PM fiber), dB	20	23	30
Fiber	-	PM-S405-XP	-
Fiber Length, m	0.95	1	1.1
Control interface type	-	UART ⁵	-
Operation mode	-	APC (CW) ⁶	-
Modulation bandwidth, MHz	-	10 ⁷	-
Input voltage, VDC	4.8	5	5.3
Input current, A	-	1.5	-
Max. power consumption, W	0.4	2	10
Heat-sinking requirement, °C/W	-	1 ⁸	-

TYPICAL NEAR FIELD

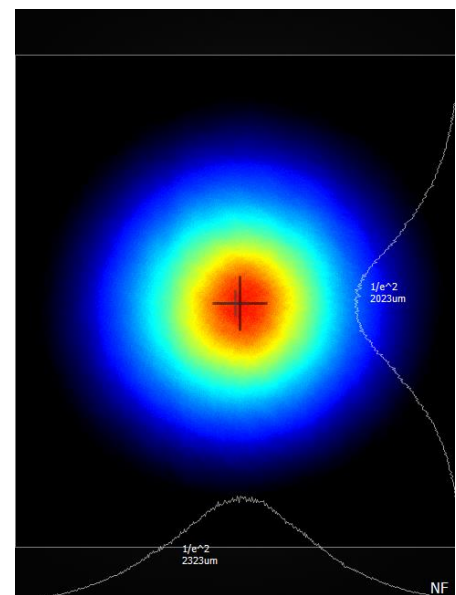

Optimum heatsink temperature, °C	15	20	30
Warm up time, mins (cold start)	0.1	0.5	1
Temperature stabilization	-	Internal TEC	-
External fan control	-	TBD ⁹	-
Overheat protection	-	Yes	-
Storage temperature, °C (non-condensing)	-10	-	50
Dimensions (WxDxH), mm	-	50 x 30 x 18 ¹⁰	-
Net weight, kg	0.1	0.12	0.14
Laser Safety Class	-	3B	-
RoHS	-	Yes	-
CE compliance	-	- General Product Safety Directive (GPSD) 2001/95/EC - (EMC) Directive 2004/108/EC	-
OEM lasers are not compliant with	-	IEC60825-1:2014 (compliant using additional accessories)	-
Warranty, months (op. hrs)	-	14 (10000) ¹¹	-
Country of origin	-	Lithuania	-

DRAWING

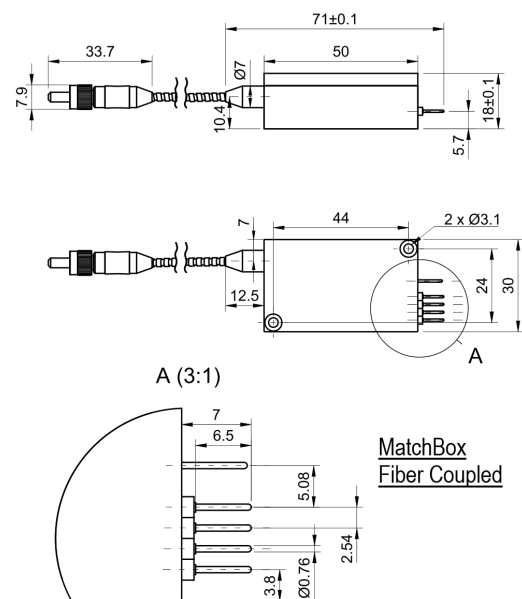

¹ The optical power can be tuned from virtually 0% to 100%. However, other specifications, such as central wavelength, power stability, noise, polarization ratio, beam shape, quality and circularity are not guaranteed at power levels other than factory preset power. Significantly worse power stability is to be expected at very low power levels, e.g. <3% from specified nominal power.

² The long term power test is carried out at constant laser body temperature (+/-0.1 °C) using an optical power meter with an input bandwidth of 10 Hz. The actual measurement rate has a period of about 20 seconds to 1 minute.

³ The long term power test is carried out at constant laser body temperature (+/-0.1 °C) using an optical power meter with an input bandwidth of 10 Hz. The actual measurement rate has a period of about 20 seconds to 1 minute.

⁴ Noise level is measured with a fast photodiode connected to an oscilloscope. The overall system bandwidth is from 2 kHz to 20 MHz.

⁵ Break-out-boxes AM-C8 and AM-C3 can be used for conversion of UART communication to either USB or RS232.

⁶ APC - Automatic Power Control.

⁷ TTL digital modulation up to 10 MHz in automatic current control (ACC) mode. TTL modulation speed in automatic power control (APC) is up to 1 kHz.

⁸ Excluding control interface pins and an output window/fiber assembly.

⁹ This function can be enabled in hardware only if the fast modulation option is disabled. The customer must specify this before ordering the laser.

¹⁰ Excluding control interface pins and an output window/fiber assembly.

¹¹ Whichever occurs first. The laser has an integrated operational hours counter.

Note: Product specifications are subject to change without prior notice to improve reliability, function or design or otherwise.