



PART NUMBER 0488L-21A
 ITEM NAME 488 NM SLM LASER (VBG DIODE; FREE-SPACE)

PRODUCT DATASHEET



DESCRIPTION

488 SLM laser diode module could be a perfect choice for Raman spectroscopy, especially for inorganic materials. Blue light lasers are widely used in surface-enhanced Raman scattering applications (SERS). Matchbox 2 modules are a perfect combination of high performance and low cost.

Note:

In optical systems with strong back-reflections (e.g. more than 10%), the laser must be protected by using an optical isolator with at least 20 dB isolation. Typical applications include interferometry, confocal microscopy (especially working with reflective samples), etc. Failure to comply with these requirements will render the warranty void for cases of COD (Catastrophic Optical Damage) of laser diode facets.

SPECIFICATIONS

Specifications updated: 4 May 2021

Parameter	Minimum Value	Typical Value	Maximum Value
Central Wavelength, nm	487.8	488	488.2
Spectral line width FWHM, pm	-	0.1 ¹	1
Output power, mW	-	30 ²	40
Power stability, % (RMS, 8 hrs)	0.02	0.05 ³	0.2
Power stability, % (peak-to-peak, 8 hrs)	0.1	0.3 ⁴	1
Intensity noise, % (RMS, 20 Hz to 20 MHz)	0.1	0.25 ⁵	0.6
Side-mode suppression ratio (SMSR), dB	40	50	60
Longitudinal modes	-	Single	-
Transversal modes	-	TEM ₀₀	-
Beam width (1/e ²), mm	-	0.8 ⁶	1.1
Beam height (1/e ²), mm	-	1.5	1.8
Horizontal beam divergence, mrad	-	1.1	1.4
Vertical beam divergence, mrad	-	0.9	1.2
M ² horizontal axis	-	1.2	1.4
M ² vertical axis	-	1.3	1.6
M ² effective	-	1.3	1.6
Polarization direction	-	Horizontal ⁷	-
Polarization contrast	1000	2000	5000
Control interface type	-	UART ⁸	-
Operation mode	-	APC (CW) ⁹	-
Modulation bandwidth, MHz	-	N/A ¹⁰	-
Input voltage, VDC	4.8	5	5.3
Input current, A	-	1.5	-

TYPICAL SPECTRUM

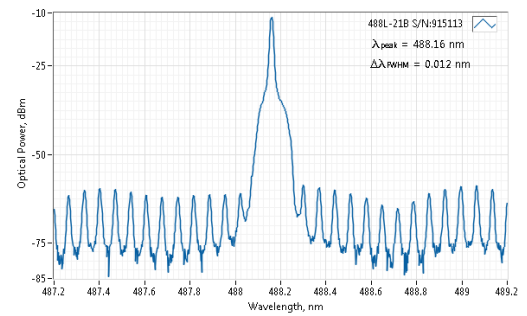

Typical spectrum of 0488 nm diode laser. Measured with 20 pm resolution.

TYPICAL NEAR FIELD

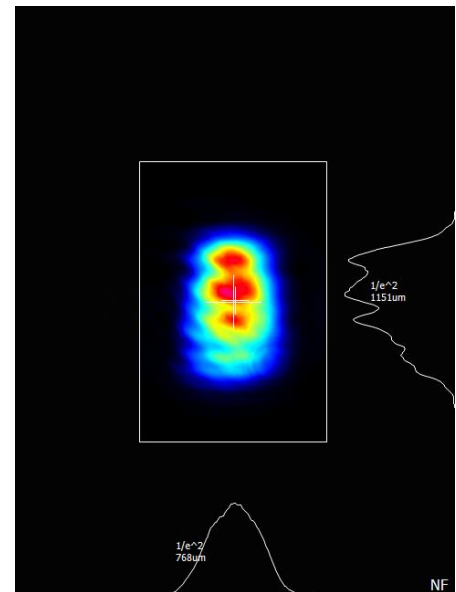

Typical near field (0.45 m from output aperture) beam profile. Non-circularized beam of a 0488 nm direct diode laser.

Max. power consumption, W	0.4	2	10
Heat-sinking requirement, °C/W	-	1	-
Optimum heatsink temperature, °C	15	20	30
Warm up time, mins (cold start)	0.2	2	2
Temperature stabilization	-	Internal TEC	-
External fan control	-	Yes	-
Overheat protection	-	Yes	-
Storage temperature, °C (non-condensing)	-10	-	50
Beam height from the base, mm	9.9	10.4	10.9
Dimensions (WxDxH), mm	-	50 x 30 x 18 ¹¹	-
Net weight, kg	0.1	0.12	0.14
Laser Safety Class	-	3B	-
RoHS	-	Yes	-
CE compliance	-	- General Product Safety Directive (GPSD) 2001/95/EC - (EMC) Directive 2004/108/EC	-
OEM lasers are not compliant with	-	IEC60825-1:2014 (compliant using additional accessories)	-
Warranty, months (op. hrs)	-	14 (10000) ¹²	-
Country of origin	-	Lithuania	-

¹ Measured with a scanning Fabry-Perot interferometer having 7.5 Mhz resolution, with scanning frequency of about 10 Hz. Interferometer testing is not provided for each laser being manufactured, the standard test is OSA measurement with 10-20 pm resolution instead.

² The output power of SLM lasers shall not be tuned and SLM performance is not guaranteed at power ratings other than factory preset. However, the power setting capability is not disabled. External attenuators are recommended instead.

³ The long term power test is carried out at constant laser body temperature (+/-0.1 °C) using an optical power meter with an input bandwidth of 10 Hz. The actual measurement rate has a period of about 20 seconds to 1 minute.

⁴ The long term power test is carried out at constant laser body temperature (+/-0.1 °C) using an optical power meter with an input bandwidth of 10 Hz. The actual measurement rate has a period of about 20 seconds to 1 minute.

⁵ Noise level is measured with a fast photodiode connected to an oscilloscope. The overall system bandwidth is from 2 kHz to 20 MHz.

⁶ Beam width and height are measured at 0.45 m from output aperture.

⁷ For lasers without integrated optical isolators.

⁸ Break-out-boxes AM-C8 and AM-C3 can be used for conversion of UART communication to either USB or RS232.

⁹ APC - Automatic Power Control.

¹⁰ SLM lasers shall not be modulated - use external modulators instead.

¹¹ Excluding control interface pins and an output window/fiber assembly.

¹² Whichever occurs first. The laser has an integrated operational hours counter.

Note: Product specifications are subject to change without prior notice to improve reliability, function or design or otherwise.

TYPICAL FAR FIELD

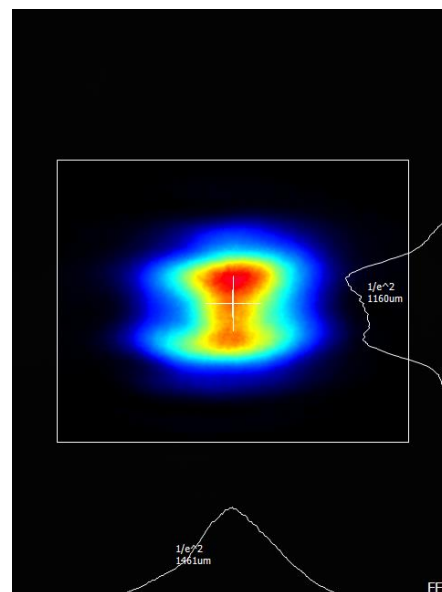

Typical far field (1 m from output aperture) beam profile. Non-circularized beam of a 0488 nm direct diode laser.

DRAWING

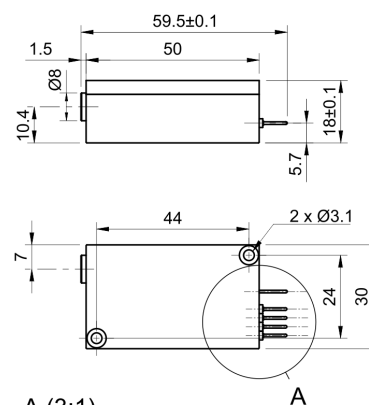

A (3:1)

MatchBox
Free-Space

