



PART NUMBER 0638L-44A
 ITEM NAME 638 NM NARROW LINEWIDTH LASER (VBG HP DIODE; MM FIBER)

PRODUCT DATASHEET



DESCRIPTION

High power 638 nm single longitudinal mode laser is designed for industrial Raman spectroscopy.

SPECIFICATIONS

Specifications updated: 18 August 2020

Parameter	Minimum Value	Typical Value	Maximum Value
Central Wavelength, nm	637.9	638	638.1
Longitudinal modes	-	Single	-
Spectral line width FWHM, pm	-	20	50
Output power, mW	-	300 ¹	-
Side-mode suppression ratio (SMSR), dB	40	50	60
Power stability, % (RMS, 8 hrs)	0.02	0.1 ²	0.25
Power stability, % (peak-to-peak, 8 hrs)	0.1	0.5 ³	1
Noise, % (RMS, 20 Hz to 20 MHz)	0.1	0.25 ⁴	0.6
Control interface type	-	UART ⁵	-
Transversal modes	-	Multiple	-
Operation mode	-	APC (CW)	-
Modulation bandwidth, MHz	-	N/A ⁶	-
Input voltage, VDC	4.8	5	5.3
External power supply requirement	-	+5 V DC, 1.5 A	-
Dimensions, mm	-	50 x 30 x 18 ⁷	-
Fiber Length, m	0.95	1	1.1
Heat-sinking requirement, °C/W	-	1	-
Optimum heatsink temperature, °C	15	20	30
Warm up time, mins (cold start)	0.2	1	2
Temperature stabilization	-	Internal TEC	-
Overheat protection	-	Yes	-
Storage temperature, °C (non-condensing)	-10	-	50

TYPICAL SPECTRUM

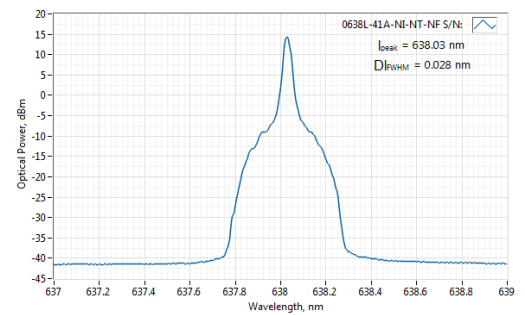

Typical spectrum of 0638 nm diode laser. Measured with 20 pm resolution.

TYPICAL NEAR FIELD

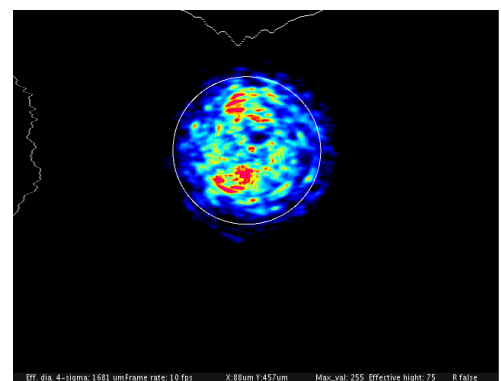

Net weight, kg	0.1	0.12	0.14
Max. power consumption, W	0.4	2	10
Warranty, months (op. hrs)	-	14 (10000) ⁸	-
RoHS	-	Yes	-
CE compliance	-	- General Product Safety Directive (GPSD) 2001/95/EC - (EMC) Directive 2004/108/EC	-
Laser Safety Class	-	3B	-
OEM lasers are not compliant with	-	IEC60825-1:2014 (compliant using additional accessories)	-
Country of origin	-	Lithuania	-

DRAWING

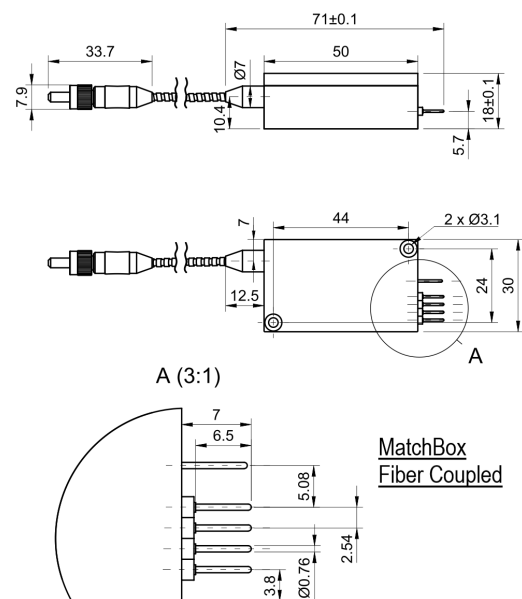

¹ The output power of SLM lasers shall not be tuned and SLM performance is not guaranteed at power ratings other than factory preset. However, the power setting capability is not disabled. External attenuators are recommended instead.

² The long term power test is carried out at constant laser body temperature (± 0.1 °C) using an optical power meter with an input bandwidth of 10 Hz. The actual measurement rate has a period of about 20 seconds to 1 minute.

³ The long term power test is carried out at constant laser body temperature (± 0.1 °C) using an optical power meter with an input bandwidth of 10 Hz. The actual measurement rate has a period of about 20 seconds to 1 minute.

⁴ Noise level is measured with a fast photodiode connected to an oscilloscope. The overall system bandwidth is from 2 kHz to 20 MHz.

⁵ Break-out-boxes AM-C8 and AM-C3 can be used for conversion of UART communication to either USB or RS232.

⁶ SLM lasers shall not be modulated - use external modulators instead.

⁷ Excluding control interface pins and an output window/fiber assembly.

⁸ Whichever occurs first. The laser has an integrated operational hours counter.

Note: Product specifications are subject to change without prior notice to improve reliability, function or design or otherwise.