



PART NUMBER 0808L-31A  
 ITEM NAME 808 NM LASER (HP DIODE; FREE-SPACE)

## PRODUCT DATASHEET



### DESCRIPTION

High power 808 nm free space laser module.

### SPECIFICATIONS

Specifications updated: 9 July 2021

| Parameter                                 | Minimum Value | Typical Value             | Maximum Value |
|---|---------------|---------------------------|---------------|
| Central Wavelength, nm                    | 802           | 808                       | 813           |
| Longitudinal modes                        | -             | Multiple                  | -             |
| Spectral line width FWHM, nm              | -             | 1                         | 2             |
| Output power, mW                          | -             | 3000 <sup>1</sup>         | -             |
| Power stability, % (RMS, 8 hrs)           | -             | 1 <sup>2</sup>            | 2             |
| Power stability, % (peak-to-peak, 8 hrs)  | -             | 2 <sup>3</sup>            | 3             |
| Intensity noise, % (RMS, 20 Hz to 20 MHz) | -             | 0.25 <sup>4</sup>         | 0.6           |
| Transversal modes                         | -             | Multiple                  | -             |
| Control interface type                    | -             | UART <sup>5</sup>         | -             |
| Operation mode                            | -             | APC (CW)                  | -             |
| Modulation bandwidth, kHz                 | -             | 1 <sup>6</sup>            | -             |
| Input voltage, VDC                        | 4.8           | 5                         | 5.3           |
| External power supply requirement         | -             | +5 V DC, 1.5 A            | -             |
| Dimensions, mm                            | -             | 50 x 30 x 18 <sup>7</sup> | -             |
| Fiber Length, m                           | 0.95          | 1                         | 1.1           |
| Heat-sinking requirement, °C/W            | -             | 1                         | -             |
| Optimum heatsink temperature, °C          | 15            | 20                        | 30            |
| Warm up time, mins (cold start)           | 0.1           | 0.5                       | 1             |
| Temperature stabilization                 | -             | Internal TEC              | -             |
| Overheat protection                       | -             | Yes                       | -             |
| Storage temperature, °C (non-condensing)  | -10           | -                         | 50            |
| Net weight, kg                            | 0.1           | 0.12                      | 0.14          |

### TYPICAL SPECTRUM

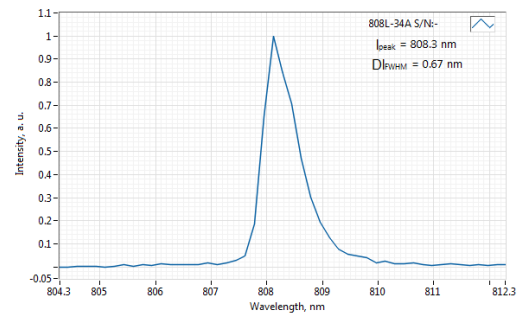

Typical spectrum of 0808 nm diode laser. Measured with 20 pm resolution.

### DRAWING

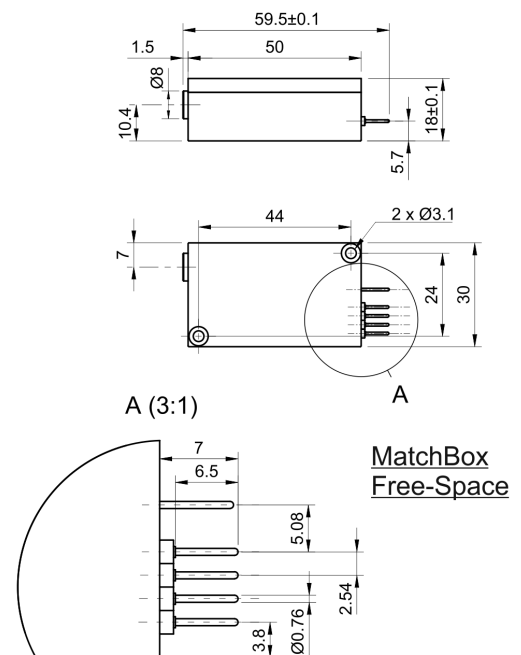

|                                   |   |   |    |
|-----------------------------------|---|---|----|
| Max. power consumption, W         | 5 | 10  | 20 |
| Warranty, months (op. hrs)        | - | 14 (10000) <sup>8</sup>   | -  |
| RoHS                              | - | Yes   | -  |
| CE compliance                     | - | - General Product Safety Directive (GPSD) 2001/95/EC<br>- (EMC) Directive 2004/108/EC | -  |
| Laser Safety Class                | - | 4   | -  |
| OEM lasers are not compliant with | - | IEC60825-1:2014 (compliant using additional accessories)                              | -  |
| Country of origin                 | - | Lithuania   | -  |

<sup>1</sup> The optical power can be tuned from virtually 0% to 100%. However, other specifications, such as central wavelength, power stability, noise, polarization ratio, beam shape, quality and circularity are not guaranteed at power levels other than factory preset power. Significantly worse power stability is to be expected at very low power levels, e.g. <3% from specified nominal power.

<sup>2</sup> The long term power test is carried out at constant laser body temperature (+/-0.1 °C) using an optical power meter with an input bandwidth of 10 Hz. The actual measurement rate has a period of about 20 seconds to 1 minute.

<sup>3</sup> The long term power test is carried out at constant laser body temperature (+/-0.1 °C) using an optical power meter with an input bandwidth of 10 Hz. The actual measurement rate has a period of about 20 seconds to 1 minute.

<sup>4</sup> Noise level is measured with a fast photodiode connected to an oscilloscope. The overall system bandwidth is from 2 kHz to 20 MHz.

<sup>5</sup> Break-out-boxes AM-C8 and AM-C3 can be used for conversion of UART communication to either USB or RS232.

<sup>6</sup> TTL digital modulation up to 10 MHz.

<sup>7</sup> Excluding control interface pins and an output window/fiber assembly.

<sup>8</sup> Whichever occurs first. The laser has an integrated operational hours counter.

Note: Product specifications are subject to change without prior notice to improve reliability, function or design or otherwise.