



PART NUMBER 1064L-25B  
 ITEM NAME 1064 NM SLM LASER (DPSS; PM FIBER)

## PRODUCT DATASHEET



### DESCRIPTION

Near infrared, 1064 nanometer DPSS laser is used in number or metrology, homeland security, and military applications. Small size and all-in-one concept of the MatchBox series makes the laser ready for integration into portable handheld devices. This particular 1064 nm narrow bandwidth laser provides 200 mW out of SM PM fiber.

#### Note:

In optical systems with strong back-reflections (e.g. more than 10%), the laser does not have to be protected by using an optical isolator, unless high laser operation stability is required. Typical applications include interferometry, confocal microscopy (especially working with reflective samples), etc.

### SPECIFICATIONS

Specifications updated: 4 May 2021

Parameter	Minimum Value	Typical Value	Maximum Value
Central Wavelength, nm	1063.7	1064	1064.3
Longitudinal modes	-	Single	-
Spectral line width FWHM, pm	-	0.2 <sup>1</sup>	1
Output power, mW	-	200 <sup>2</sup>	250
Side-mode suppression ratio (SMSR), dB	40	50	60
Power stability, % (RMS, 8 hrs)	0.02	0.1 <sup>3</sup>	0.3
Power stability, % (peak-to-peak, 8 hrs)	0.1	0.5 <sup>4</sup>	1.5
Intensity noise, % (RMS, 20 Hz to 20 MHz)	0.3	0.5 <sup>5</sup>	1.5
Transversal modes	-	TEM00	-
Polarization direction	-	Aligned within the slow axis of the PM fiber and the key position	-
Polarization extinction ratio (from PM fiber), dB	20	23	30
Control interface type	-	UART <sup>6</sup>	-
Operation mode	-	APC (CW)	-
Modulation bandwidth, MHz	-	N/A <sup>7</sup>	-
Input voltage, VDC	4.8	5	5.3
External power supply requirement	-	+5 V DC, 5 A	-
Dimensions, mm	-	50 x 30 x 18 <sup>8</sup>	-
Fiber Length, m	0.95	1	1.1
Heat-sinking requirement, °C/W	-	0.5	-
Optimum heatsink temperature, °C	15	20	30

### TYPICAL SPECTRUM

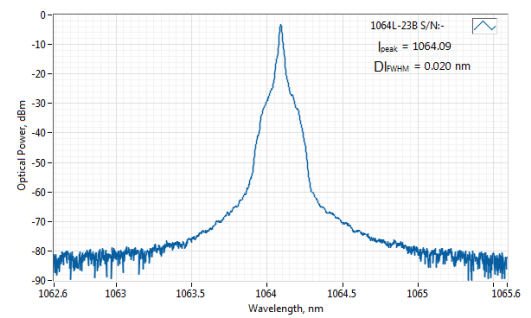

Typical spectrum of 1064 nm DPSS laser. Measured with 20 pm resolution.

### TYPICAL NEAR FIELD

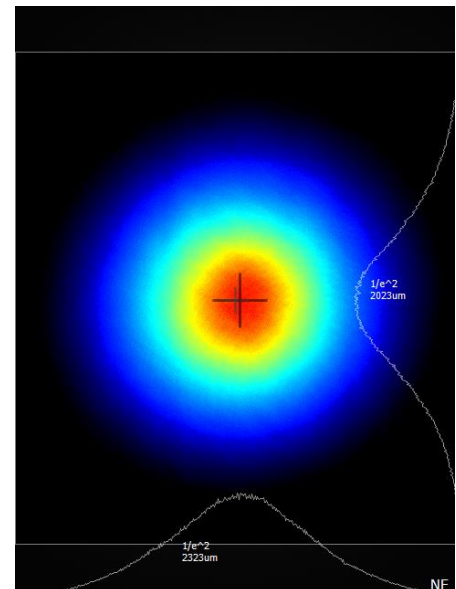

Warm up time, mins (cold start)	1	3	5
Temperature stabilization	-	Internal TEC	-
Overheat protection	-	Yes	-
Storage temperature, °C (non-condensing)	-10	-	50
Net weight, kg	0.1	0.12	0.14
Max. power consumption, W	5	10	20
Warranty, months (op. hrs)	-	14 (10000) <sup>9</sup>	-
RoHS	-	Yes	-
CE compliance	-	- General Product Safety Directive (GPSD) 2001/95/EC - (EMC) Directive 2004/108/EC	-
Laser Safety Class	-	3B	-
OEM lasers are not compliant with	-	IEC60825-1:2014 (compliant using additional accessories)	-
Country of origin	-	Lithuania	-

## DRAWING

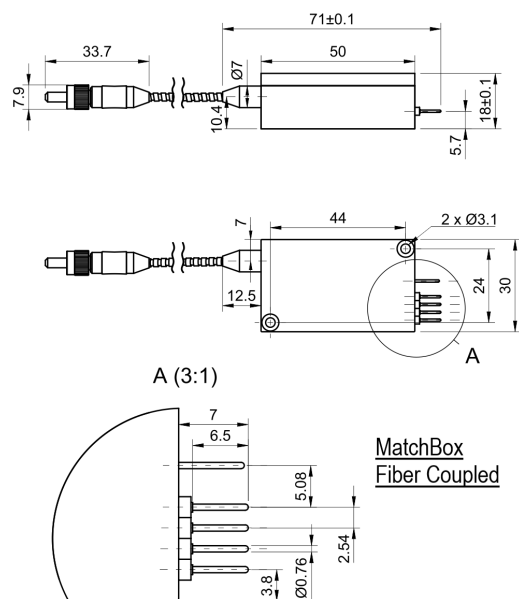

<sup>1</sup> Measured with a scanning Fabry-Perot interferometer having 7.5 Mhz resolution, with scanning frequency of about 10 Hz. Interferometer testing is not provided for each laser being manufactured, the standard test is OSA measurement with 10-20 pm resolution instead.

<sup>2</sup> The optical power of SLM lasers shall not be tuned and SLM performance is not guaranteed at power ratings other than the factory preset. However, the power setting capability is not disabled. External attenuators are recommended.

<sup>3</sup> The long term power test is carried out at constant laser body temperature (+/-0.1 °C) using an optical power meter with an input bandwidth of 10 Hz. The actual measurement rate has a period of about 20 seconds to 1 minute.

<sup>4</sup> The long term power test is carried out at constant laser body temperature (+/-0.1 °C) using an optical power meter with an input bandwidth of 10 Hz. The actual measurement rate has a period of about 20 seconds to 1 minute.

<sup>5</sup> Noise level is measured with a fast photodiode connected to an oscilloscope. The overall system bandwidth is from 2 kHz to 20 MHz.

<sup>6</sup> Break-out-boxes AM-C8 and AM-C3 can be used for conversion of UART communication to either USB or RS232.

<sup>7</sup> SLM lasers shall not be modulated - use external modulators instead.

<sup>8</sup> Excluding control interface pins and an output window/fiber assembly.

<sup>9</sup> Whichever occurs first. The laser has an integrated operational hours counter.

Note: Product specifications are subject to change without prior notice to improve reliability, function or design or otherwise.