



PART NUMBER 1319L-11B  
 ITEM NAME 1319 NM LASER (DPSS; FREE-SPACE)

## PRODUCT DATASHEET



### DESCRIPTION

Compact 1319 nm free-space laser is a DPSS module used in numerous applications, such as inspection, optical guiding, infrared absorption. The small size and all-in-one concept of the MatchBox series make the laser ready for integration into portable handheld devices.

### SPECIFICATIONS

Specifications updated: 7 December 2021

Parameter	Minimum Value	Typical Value	Maximum Value
Central Wavelength, nm	1318	1319	1320
Longitudinal modes	-	Multiple	-
Spectral line width FWHM, nm	0.1	0.7	1
Output power, mW	-	200 <sup>1</sup>	-
Power stability, % (RMS, 8 hrs)	0.05	0.2 <sup>2</sup>	1
Power stability, % (peak-to-peak, 8 hrs)	0.1	2 <sup>3</sup>	3
Intensity noise, % (RMS, 20 Hz to 20 MHz)	0.5	3 <sup>4</sup>	30
Transversal modes	-	TEM <sub>00</sub>	-
Beam width (1/e <sup>2</sup> ), mm	-	1 <sup>5</sup>	-
Beam height (1/e <sup>2</sup> ), mm	-	1	-
Horizontal beam divergence, mrad	-	2.3	-
Vertical beam divergence, mrad	-	2.4	-
M <sup>2</sup> effective	-	1.1	1.3
Polarization direction	-	Horizontal <sup>6</sup>	-
Polarization contrast	500	1000	2000
Control interface type	-	UART <sup>7</sup>	-
Operation mode	-	APC (CW)	-
Modulation bandwidth, MHz	-	N/A <sup>8</sup>	-
Input voltage, VDC	4.8	5	5.3
External power supply requirement	-	+5 V DC, 5 A	-
Dimensions, mm	-	50 x 30 x 18 <sup>9</sup>	-
Beam height from the base, mm	9.9	10.4	10.9
Heat-sinking requirement, °C/W	-	0.5	-

### TYPICAL SPECTRUM

Spectrum of 1319 nm Laser (DPSS; Free-space)

Typical spectrum of 1319 nm DPSS laser. Measured with 20 pm resolution.

### DRAWING

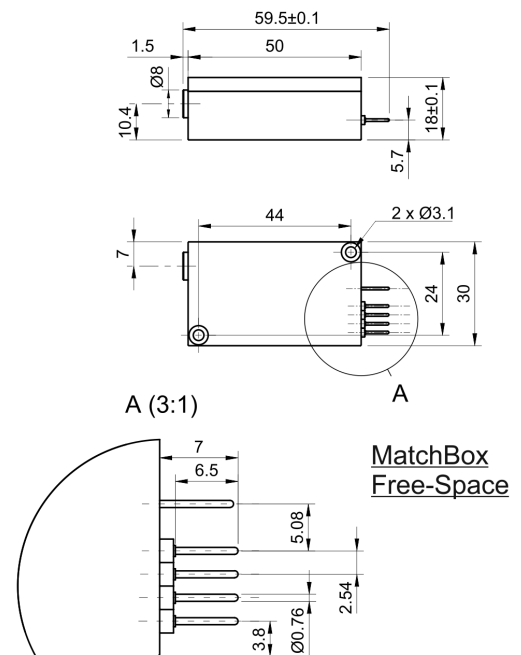

Optimum heatsink temperature, °C	15	20	30
Warm up time, mins (cold start)	0.2	1	2
Temperature stabilization	-	Internal TEC	-
Overheat protection	-	Yes	-
Storage temperature, °C (non-condensing)	-10	-	50
Net weight, kg	0.1	0.12	0.14
Max. power consumption, W	5	10	20
Warranty, months (op. hrs)	-	14 (10000) <sup>10</sup>	-
RoHS	-	Yes	-
CE compliance	-	- General Product Safety Directive (GPSD) 2001/95/EC - (EMC) Directive 2004/108/EC	-
Laser Safety Class	-	3B	-
OEM lasers are not compliant with	-	IEC60825-1:2014 (compliant using additional accessories)	-
Country of origin	-	Lithuania	-

<sup>1</sup> The optical power can be tuned from virtually 0% to 100%. However, other specifications, such as central wavelength, power stability, noise, polarization ratio, beam shape, quality and circularity are not guaranteed at power levels other than factory preset power. Significantly worse power stability is to be expected at very low power levels, e.g. <3% from specified nominal power.

<sup>2</sup> The long term power test is carried out at constant laser body temperature (+/-0.1 °C) using an optical power meter with an input bandwidth of 10 Hz. The actual measurement rate has a period of about 20 seconds to 1 minute.

<sup>3</sup> The long term power test is carried out at constant laser body temperature (+/-0.1 °C) using an optical power meter with an input bandwidth of 10 Hz. The actual measurement rate has a period of about 20 seconds to 1 minute.

<sup>4</sup> Noise level is measured with a fast photodiode connected to an oscilloscope. The overall system bandwidth is from 2 kHz to 20 MHz.

<sup>5</sup> Beam width and height are measured at 0.45 m from output aperture.

<sup>6</sup> For lasers without integrated optical isolators.

<sup>7</sup> Break-out-boxes AM-C8 and AM-C3 can be used for conversion of UART communication to either USB or RS232.

<sup>8</sup> Modulation of DPSS lasers is limited to a few kHz by physics. Therefore we recommend to modulate the laser by sending commands through UART interface. The TTL pin of DPSS lasers is configured to provide PWM signal for control of fan speed instead of modulation.

<sup>9</sup> Excluding control interface pins and an output window/fiber assembly.

<sup>10</sup> Whichever occurs first. The laser has an integrated operational hours counter.

Note: Product specifications are subject to change without prior notice to improve reliability, function or design or otherwise.