

## 850nm 4W VCSEL Diode with Diffuser VD-0850I-004W-1C-5AX

### FEATURES

- Single wavelength
- Good thermal conduction
- Short rise time
- Oxide isolation technology
- High reliability

### APPLICATIONS

- 3D sensors
- Lidars
- IR illuminations
- Medical applications
- Proximity sensors

Part Number	Description
VD-0850I-004W-1C-5AX	850nm 4W VCSEL Diode with Diffuser

### PRODUCT IDENTIFY

#### Code Rules

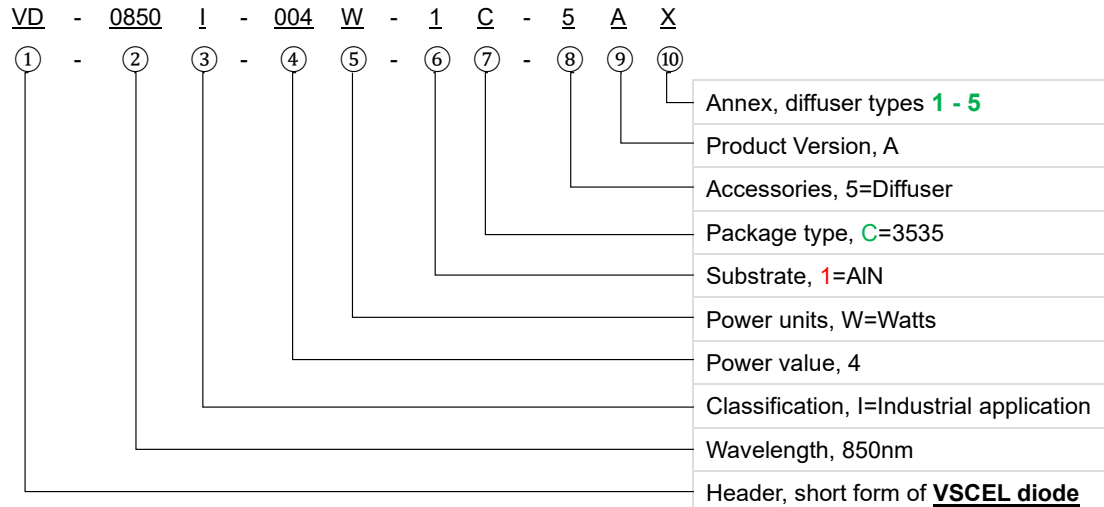

Part number	Diffuser types	Description (Horizontal×Vertical)
VD-0850I-004W-1C-5A(X)		
VD-0850I-004W-1C-5A1	6045	60° × 45°
VD-0850I-004W-1C-5A2	7258	72° × 58°
VD-0850I-004W-1C-5A3	9070	90° × 70°
VD-0850I-004W-1C-5A4	B085	110° × 85°
VD-0850I-004W-1C-5A5	C090	120° × 90°



www.rpmclasers.com

### I. Absolute maximum ratings

Parameter	Symbol	Rating	Unit
Case Operating Temperature	T <sub>op</sub>	-40 to +85	°C
Storage Temperature	T <sub>sto</sub>	-40 to +105	°C
Reflow Soldering Temperature	T <sub>sdr</sub>	260°C (10s)	/
Reverse Voltage	V <sub>r</sub>	5	V
Maximum Continuous Current	I <sub>max</sub>	6	A
ESD exposure (Human body) model	ESD	2K	V

**Note:**

1. Stresses greater than those listed under “Absolute Maximum Ratings” may cause permanent damage to the device. This is a stress rating only and functional operation of the device at these or other conditions above those indicated in the operations section for extended periods of time may affect reliability.
2. In its maximum rating diode laser operation could damage its performance or cause potential safety hazard such as equipment failure.
3. Electrostatic discharge is the main reason for the laser fault of the diode. Take effective precautions against ESD. When dealing with laser diodes, use the wrist strap, grounding work surface and strict antistatic technology.

### II. Optical-electrical characteristics @25°C , Pulse Width 0.1ms, Duty Cycle1%

Parameters	Symbol	Condition	Min.	Typ.	Max.	Unit
Threshold Current	I <sub>th</sub>		-	600	-	mA
Forward Current	I <sub>F</sub>		-	4.5	-	A
Optical Power	P <sub>o</sub>	I <sub>F</sub> =4.5A	-	4	-	W
Laser Forward Voltage	V <sub>f</sub>	I <sub>F</sub> =4.5A	-	2.3	-	V
Power conversion efficiency	η	I <sub>F</sub> =4.5A	-	39	-	%
Slope efficiency	SE	P <sub>o</sub> =4W	-	1.03	-	W/A
Series Resistance	R	I <sub>F</sub> =4.5A	-	0.51	-	Ω
Peak Wavelength	-	I <sub>F</sub> =4.5A	840	850	860	nm
Wavelength-Temp. Drift	Δλ/ΔT	I <sub>F</sub> =4.5A	-	-	0.07	nm/°C
Beam divergence (without diffuser)	FWHM <sub>B</sub>			20		deg

**Note:** Electro-Optical Characteristic with a package or diffuser would require further evaluation. Values are based on limited sample size and estimated values.

#### IV. Mechanical Schematics

VD-0850I-004W-1C-5AX with Substrate 1=AIN and Package C=3535 (unit: mm)

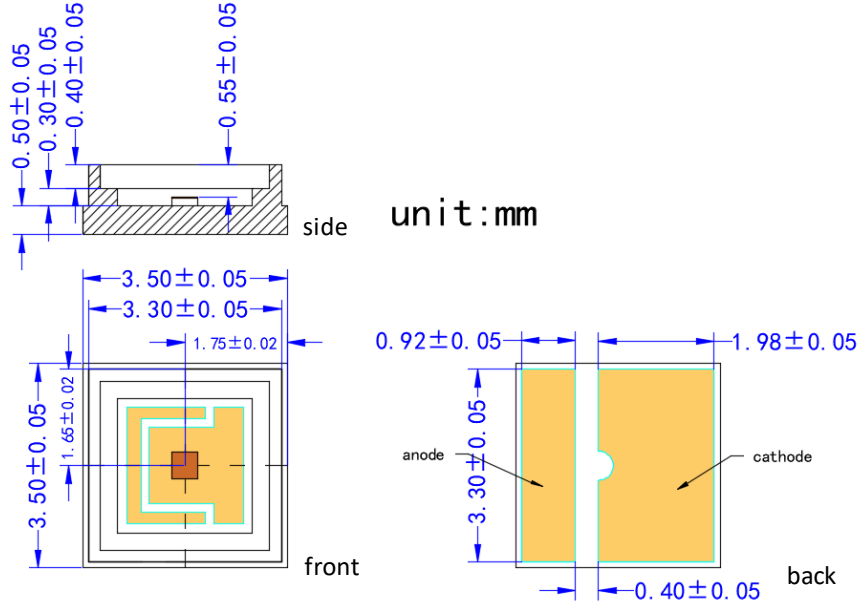

**Note:** There may be some changes between sample and drawing · thus · the actual spec please refer to the sample that you received. And if any inquires please contact us.

#### V. SMT Reflow Soldering Curve

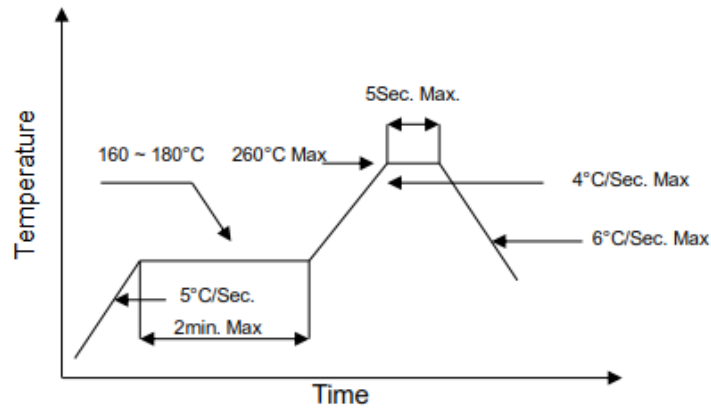

**Note:** Reflow soldering can be operated only one time. During the temperature ramp-up, no forces may be exerted on the diode which could deform or damage them. After soldering completed, please also do not process until the product temperature ramp down to room temperature.

#### VI. Treatment and protection measures

##### Soldering precautions

The temperature of soldering iron must be controlled under  $300^\circ\text{C}$  during manual soldering. Also, VCSEL can be only soldered one time with the soldering time less than 3s. but, it is very hard to

**IV. Mechanical Schematics**

VD-0850I-004W-1C-5AX with Substrate 1=AIN and Package C=3535 (unit: mm)

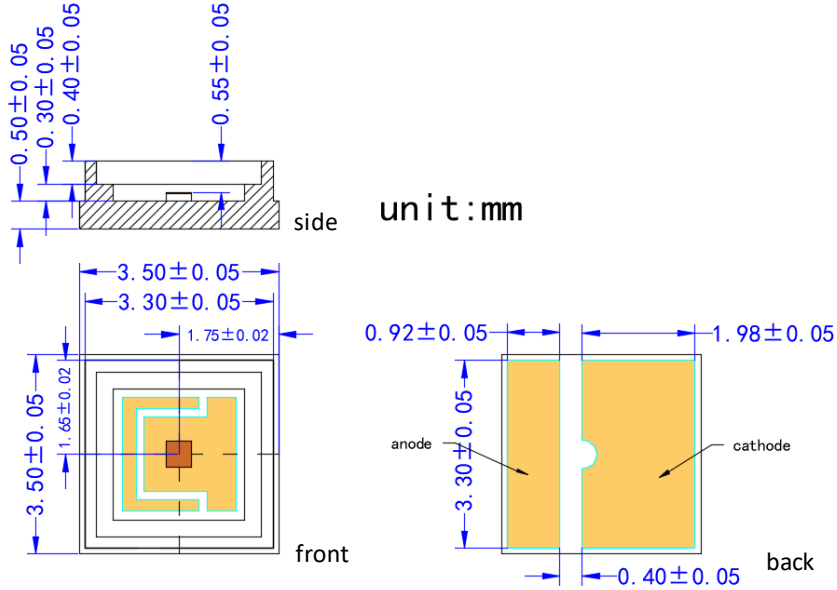

**Note:** There may be some changes between sample and drawing · thus · the actual spec please refer to the sample that you received. And if any inquires please contact us.

**V. SMT Reflow Soldering Curve**

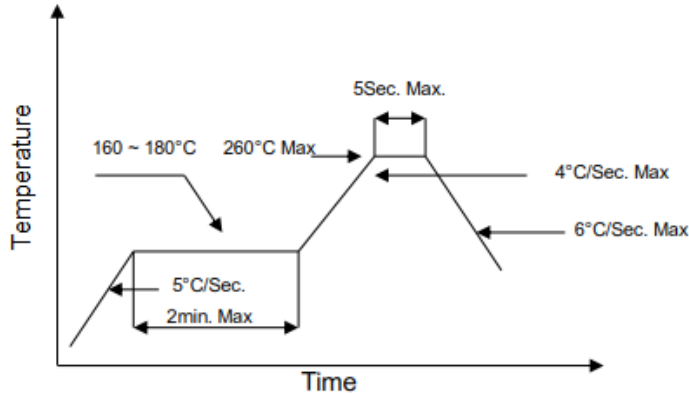

**Note:** Reflow soldering can be operated only one time. During the temperature ramp-up, no forces may be exerted on the diode which could deform or damage them. After soldering completed, please also do not process until the product temperature ramp down to room temperature.

**VI. Treatment and protection measures**

**Soldering precautions**

The temperature of soldering iron must be controlled under  $300^\circ\text{C}$  during manual soldering. Also, VCSEL can be only soldered one time with the soldering time less than 3s. but, it is very hard to



www.rpmclasers.com

control the soldering temperature and homogenize solder paste because of the smaller size of VCSEL. In addition, it is easy to damage VCSEL structure even causes VCSEL losing efficacy. So, we advise you to use re-flow soldering machine for operation.

**Storage precautions**

Our products were sealed by aluminum foil bag attaching packed desiccant, they are moisture proof and anti-static. Please handle these gently to avoid damage. At the same time, please be ready for storage and take some moisture-proof measures to keep the diode away from dampness that may causes reliability failure.

Before opening, the diode must be saved for at least 90 days below 30 °C with 60% RH.

After opening, the diode must be kept in an environment that temperature lower than 30 °C and humidity lower than 60% RH and used up within 24 hours. When the storage humidity reaches and exceeds 60%, the products must be dehumidified at 60 °C for more than 24 hours before use.

**Others**

1. Please use solder paste to cure the laser diode.
2. Please make sure that the heat of the diode has been completely conducted to metal shell, to avoid affecting the optical power output.
3. This diode can be only used in constant voltage and current.
4. Operating voltage and current, refer to the table in paragraph II.
5. Please do not aim the laser to people or animal.
6. You can observe the laser spot through an image monitoring equipment.
7. Please do not touch the diode surface by naked hands or squeeze the sealant on the diode surface, or it may cause wrong optical angle and distorted laser spot, even damage the diode.
8. Please use ceramic suction nozzle to absorb the diode, to avoid the diode sticking to the nozzle.
9. Please add a 0.02 s blowing action after locating the laser diode to aluminum substrate.

**VII. Revision History**

Revision	Date	Description
V.01	2020/01/20	The first official edition
V.02	2020/05/19	Update part name (0014C1)

**Note:** Brightlaser reserves the right to make modification at any time due to improved design from time to time, the merit behind is to supply the best product possible.