



PART NUMBER 0450L-36A
 ITEM NAME 450 NM LASER (DIODE; SMA PORT)

PRODUCT DATASHEET



DESCRIPTION

This is a multimode high-power blue diode with more than 600 mW output power. 450 nm laser diode module with an SMA port is an excellent choice for multimode fiber installations, such as flow cytometry, fluorescence, and biomedical applications. Small footprint, stable power, low power consumption are only a few advantages of this laser. Multimode fiber can be supplied upon request.

SPECIFICATIONS

Specifications updated: 28 December 2022

Parameter	Minimum Value	Typical Value	Maximum Value
Central Wavelength, nm	440	450	460
Longitudinal modes	-	Multiple	-
Spectral line width FWHM, nm	0.9	1.4	2
Output power, mW	-	300 ¹	-
Power stability, % (RMS, 8 hrs)	0.05	0.1 ²	1
Power stability, % (peak-to-peak, 8 hrs)	0.5	1 ³	2
Intensity noise, % (RMS, 20 Hz to 20 MHz)	0.2	0.25 ⁴	3
Transversal modes	-	Multiple	-
Control interface type	-	UART ⁵	-
Operation mode	-	ACC (CW)	-
Modulation bandwidth, kHz	-	1	-
Input voltage, VDC	4.8	5	5.3
External power supply requirement	-	+5 V DC, 2 A	-
Dimensions, mm	-	50 x 30 x 18 ⁶	-
Heat-sinking requirement, °C/W	-	0.5	-
Optimum heatsink temperature, °C	15	20	30
Warm up time, mins (cold start)	0.1	0.5	1
Temperature stabilization	-	Internal TEC	-
Overheat protection	-	Yes	-
Storage temperature, °C (non-condensing)	-10	-	50
Net weight, kg	0.1	0.12	0.14
Max. power consumption, W	5	10	20

TYPICAL SPECTRUM

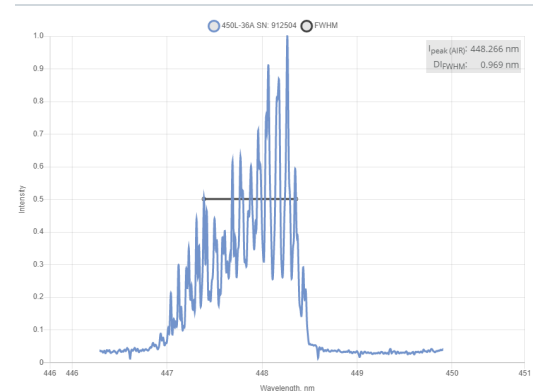

Typical spectrum of 0450 nm diode laser. Measured with 10 pm resolution.

TYPICAL NEAR FIELD

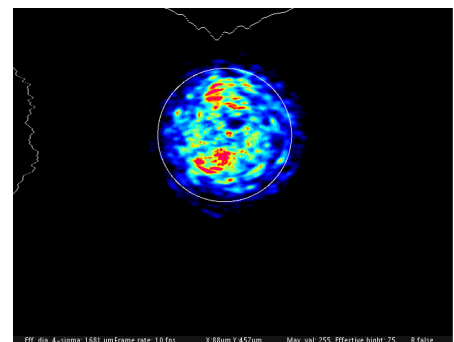

Eff. dia. 4-sigma: 1681 um Frame rate: 1.0 fps X: 88um Y: 457um Max_val: 255 Effective height: 75 R: false

Warranty, months (op. hrs)	-	14 (10000) ⁷	-
RoHS	-	Yes	-
CE compliance	-	- General Product Safety Directive (GPSD) 2001/95/EC - (EMC) Directive 2004/108/EC	-
Laser Safety Class	-	4	-
OEM lasers are not compliant with	-	IEC60825-1:2014 (compliant using additional accessories)	-
Country of origin	-	Lithuania	-

DRAWING

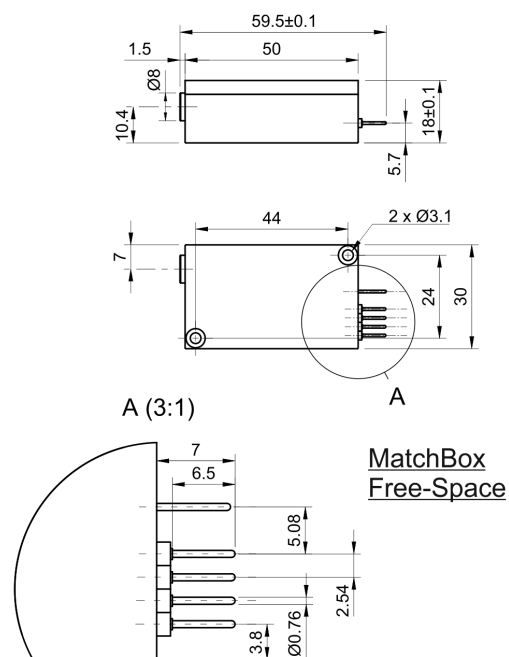

¹ The optical power can be tuned from virtually 0% to 100%. However, other specifications, such as central wavelength, power stability, noise, polarization ratio, beam shape, quality and circularity are not guaranteed at power levels other than factory preset power. Significantly worse power stability is to be expected at very low power levels, e.g. <3% from specified nominal power.

² The long term power test is carried out at constant laser body temperature (± 0.1 °C) using an optical power meter with an input bandwidth of 10 Hz. The actual measurement rate has a period of about 20 seconds to 1 minute.

³ The long term power test is carried out at constant laser body temperature (± 0.1 °C) using an optical power meter with an input bandwidth of 10 Hz. The actual measurement rate has a period of about 20 seconds to 1 minute.

⁴ Noise level is measured with a fast photodiode connected to an oscilloscope. The overall system bandwidth is from 2 kHz to 20 MHz.

⁵ Break-out-boxes AM-C8 and AM-C3 can be used for conversion of UART communication to either USB or RS232.

⁶ Excluding control interface pins and an output window/fiber assembly.

⁷ Whichever occurs first. The laser has an integrated operational hours counter.

Note: Product specifications are subject to change without prior notice to improve reliability, function or design or otherwise.