

## 808nm 60W High Power Fiber Coupled Diode Laser

### RPK808-N1-60.00W-10522-SM (Optional Product)

---

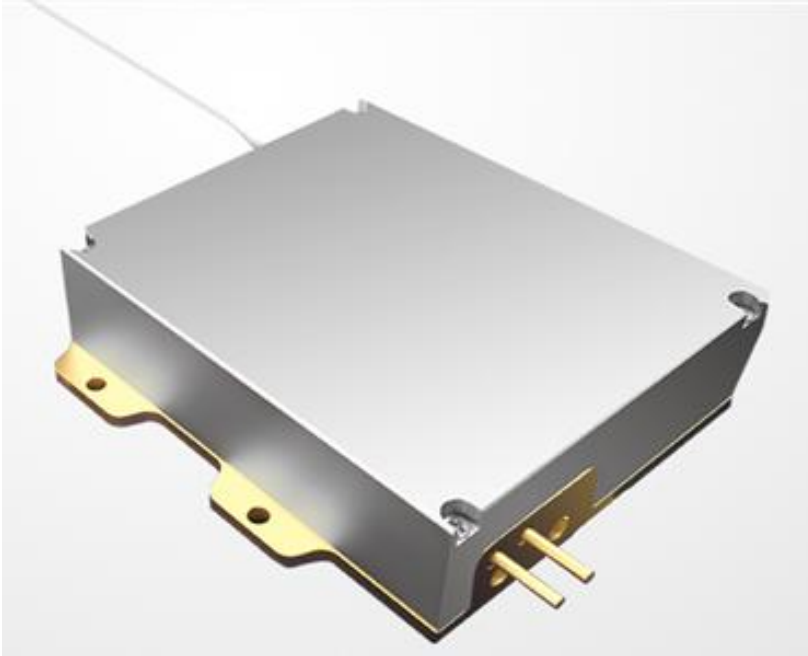

#### Features:

- ◆ 808nm wavelength
- ◆ 60W output power
- ◆ 106.5 $\mu$ m fiber core diameter
- ◆ 0.22 NA

#### Applications:

- ◆ DPSS pumping
- ◆ Medical use
- ◆ Material processing

Our high power diode laser modules are manufactured by adopting specialized fiber-coupling techniques, resulting in volume products with a high efficiency, stability and superior beam quality. The products are achieved by transforming the asymmetric radiation from the laser diode chip into an output fiber with small core diameter by using special micro optics. Inspecting and burn-in procedures in every aspect come to a result to guarantee each product with the reliability, stability and long lifetime.

Our research staff is constantly improving and innovating the processing technology in the producing process, based on the professional knowledge and experience accumulated in long-terms. We are also continuously developing new products to meet customers' specific needs.

## 808nm 60W High Power Fiber Coupled Diode Laser

### RPK808-N1-60.00W-10522-SM (Optional Product)

Specifications(25°C)		Symbol	Unit	RPK808-N1-60.00W-10522-SM		
				Minimum	Typical	Maximum
Optical Data <sup>(1)</sup>	CW Output Power	P <sub>o</sub>	W	60	-	-
	Center wavelength	λ <sub>c</sub>	nm	808±3		
	Spectral width(FWHM)	Δλ	nm	-	6	-
	Wavelength Shift with Temperature	Δλ/ΔT	nm/°C	-	0.3	-
	Wavelength Shift with Current	Δλ/ΔA	nm/A	-	1	-
Electrical Data	Electrical-to-Optical Efficiency	PE	%	-	42	-
	Operating current	I <sub>th</sub>	A	-	-	5.5
	Threshold current	I <sub>op</sub>	A	-	0.85	-
	Operating voltage	V <sub>op</sub>	V	-	28.4	29
	Slope Efficiency	η	W/A	-	13	-
Fiber Data	Buffer diameter	D <sub>buf</sub>	μm	-	250	-
	Cladding diameter	D <sub>clad</sub>	μm	-	125	-
	Core diameter	D <sub>core</sub>	μm	-	106.5	-
	Numeric aperture	NA	-	-	0.22	-
	Fiber length	l <sub>c</sub>	m	-	2	-
	Fiber Loose Tubing Diameter/Length	-	-	1mm PTFE 180cm		
	Minimum Bending Radius	-	-	60	-	-
	Fiber termination	-	mm	-	FPT	-
Feedback Isolation	Back reflection wavelength Range	λ	nm	1040~1200		
	Back reflection isolation	-	dB	-	30	-
Thermistor	-	R <sub>t</sub>	(K Ω)/β(25°C)	-	10±3%/3477	-
Others	ESD	-	V	-	-	500
	Storage temperature <sup>(2)</sup>	-	°C	-20	-	70
	Lead Soldering Temp	T <sub>is</sub>	°C	-	-	260
	Lead Soldering Time	T <sub>is</sub>	sec	-	-	10
	Operating case temperature <sup>(3)</sup>	T <sub>op</sub>	°C	15	-	35
	Relative Humidity	-	%	15	-	75

(1) Data measured under operation output at 60W@25°C.

(2) A non-condensing environment is required for operation and storage.

(3) Operating temperature defined by the package case. Acceptable operating range is 15~35°C, but performance may vary.

## 808nm 60W High Power Fiber Coupled Diode Laser

### RPK808-N1-60.00W-10522-SM

#### Package Dimensions (mm)

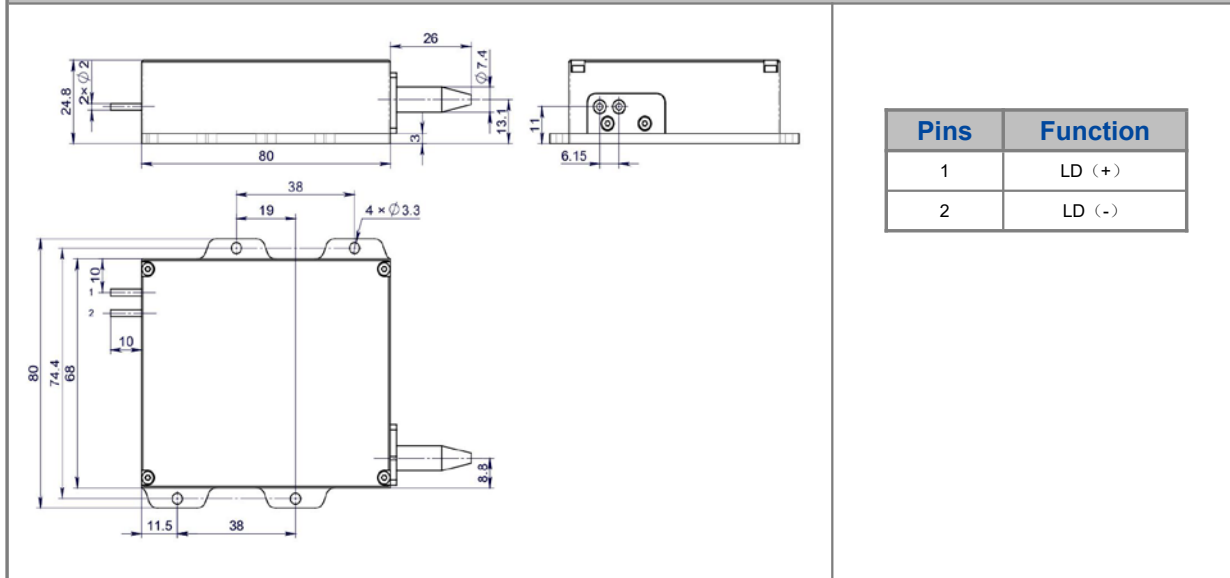

#### OPERATING NOTES

- ◆ Avoid eye and skin exposure to direct radiation during operation.
- ◆ ESD precautions must be taken during storage, transportation and operation.
- ◆ Short-circuit is required between pins during storage and transportation.
- ◆ Please connect pins to wires by solder instead of using socket when operation current is higher than 6A. Soldering point should be close to the root of the pins. Soldering temperature should be lower than 260°C and time shorter than 10 second.
- ◆ Make sure the fiber output end is properly cleaned before operation of laser. Follow safety protocols to avoid injury when handling and cutting the fiber.
- ◆ Use constant current power supply to avoid surge current during operation.
- ◆ Laser diode must be used according to the specifications.
- ◆ Laser diode must work with good cooling.
- ◆ Operation temperature ranges from 15°C to 35°C .
- ◆ Storage temperature ranges from -20°C to +70°C .



**Declaration:** information and specifications contained herein are deemed to be reliable and accurate. BWT Beijing reserves the right to change, alter or modify the design and specifications of these products at any time without notice.19-1