

Blue Laser

Model: RPKBDL-CW2000-E600

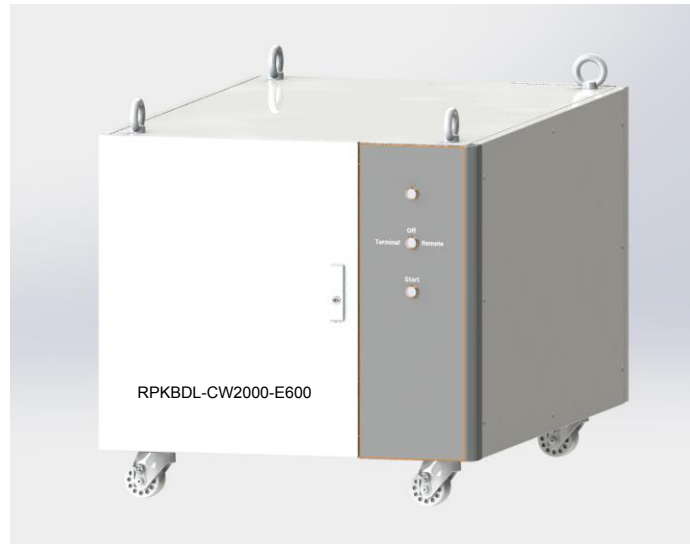

FEATURES

- Good beam quality
- Excellent power stability
- Excellent system reliability
- Easy-to-use control interface
- High electro-optical conversion efficiency
- Two operation modes: CW and Modulation
- Max modulation frequency up to 5kHz
- Cost effective and maintenance free

APPLICATION

- Welding
- Surface treatment
- Additive manufacturing
- Lithium ion battery manufacturing

Compared with traditional laser product, our blue laser direct diode laser has a higher absorption rate for materials such as copper and aluminum, and can process non-ferrous metals with lower power. Our blue laser is a more compact and easy to use product. With flexible laser output mode, it can be integrated into the processing system conveniently.

Our blue lasers can be used in wide application like welding, cladding, surface treatment, lithium-ion battery manufacturing, etc.

Our professional laser application team, with good knowledge and experience, provides the best laser system solution for our customers all around the world.

SPECIFICATIONS

Optical Character	
Power	2000W
Wavelength	450±5 nm
Output Fiber Core Diameter	600 μm
Output Cable Length	5 m or Customized
Output Cable Connector	QBH
Aiming Beam	Red
Operation Mode	CW or modulation
Polarization	Random
Power Stability (25°C)	<±1.5% (2h)
Power Adjustment Scope	10%-100%
Max Modulation Frequency	5kHz
Size and Weight	
Physical Size (H×W×D)	800mm*750mm*1200mm
Weight	< 140 kg
Electronic Character	
Power Supply	Three Phase, 380±20 V, AC, PE, 50/60 Hz
Power Consumption	10.0 kW
Control Interface	RS232/AD
Water Cooling Parameters	
Minimum Water Cooling Capacity	8.0 kW
Temperature Settings	25°C (Laser Module), 30°C (QBH)
Cooling Tubes Size	I.D. Φ32mm
Cooling Water Flow Rate (Laser Module)	>50 L/min
Cooling Water Flow Rate (QBH)	1.5~2.0L/min

Note: The back reflection will affect the performance and life of the direct diode laser. It is necessary to use the output laser when it is 8-10° away from the vertical direction of the surface.

DEMINSIONS (mm)

