

High Power RSOA Chip on Carriers

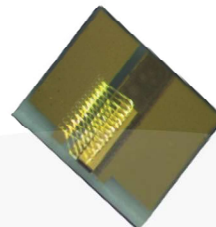

Part Number: COC-289

High Power RSOA Chip on Carrier
Single-Mode RSOA Fabry-Perot
Wavelength at 1310nm



Features

- High Output Power
- High Dynamic Range
- High Efficiency
- Standard RSOA Chip on Carrier
- Cost Effective

Application

- OTDR
- LiDAR
- Free Space Communications
- Network Test Equipment



SemiNex delivers the highest available power at infrared wavelengths between 12xx and 19xx nm. When necessary, we will further optimize the design of our InP laser chips to meet our customers' specific optical and electrical performance needs. Diodes, bars and packages are tested to meet customer and market performance demands. Typical results and packaging options are shown. Contact SemiNex for additional details or to discuss your specific requirements.

High Power RSOA Chip on Carriers



Specification

COC-289

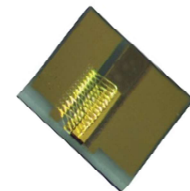

Optical	Symbol	Typ.	Units
Center Wavelength	λ_c	1310	nm
Output Power @1A*	P_{out}	0.45	Watts ($\pm 10\%$)
Aperture Width	AW	4	μm
Aperture Height	AH	1	μm
Spectral Width	$\delta\lambda$	85	nm @ 3dB
Gain @ Pin = 10	G	40	dB
Beam Exit Angle	θ_{EXT}	19.5	Degree
Noise Figure	NF	6	dB
Polarization Extinction Ratio	PER	18	dB
Fast Axis Div.	θ_{\perp}	30	Deg FWHM
Slow Axis Div.	θ_{\parallel}	16	Deg FWHM
Front Facet Reflectivity		<0.1%	
Rear Face Reflectivity		<0.1%	
Waveguide		Curved	
Electrical	Symbol		Units
Operating Current	I_{op}	2	A
Operating Voltage	V_{op}	1	V
Mechanical	Symbol	Range	Units
Chip Width		500	μm
Operating Temp.**	$^{\circ}C$	-40 to 100	$^{\circ}C$
Storage Temp.	$^{\circ}C$	-40 to 100	$^{\circ}C$

*Optical Power for 1310nm Chips CHP-288 and CHP-290 has an SOA current @ 1.2A and Pin @ 7mW
 *Optical Power for 1550nm Chips CHP-285 and CHP-287 has an SOA current @ 1.4A and Pin @ 36mW

*Specified values are rated at a constant heat sink temperature of 20°C.
 **High temperature operation will reduce performance and MTTF.
 Unless otherwise indicated all values are nominal.

High Power RSOA Chip on Carriers



SemiNex Laser Diodes COC-289

Graphs & Data

Typical RSOA COC L-I-V Characteristics

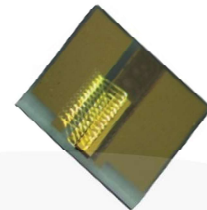
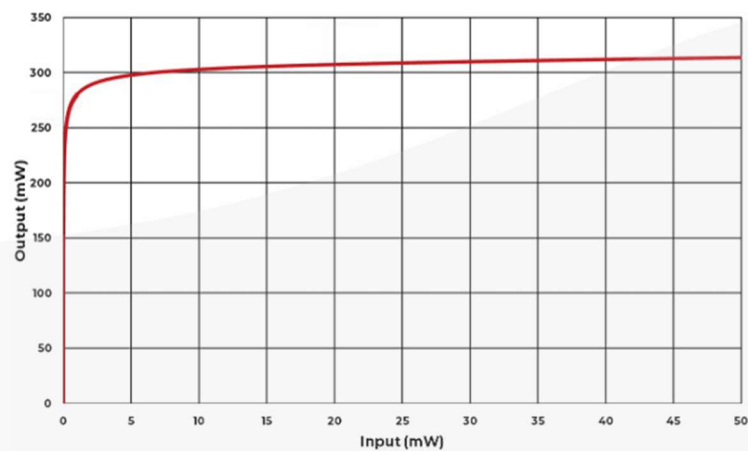

Typical RSOA COC Output Spectrum

*Graphs and Data were collected from mounted parts

High Power RSOA Chip on Carriers



Mechanical Drawing

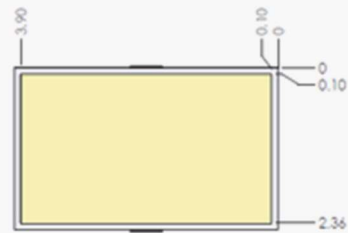
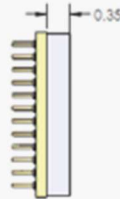
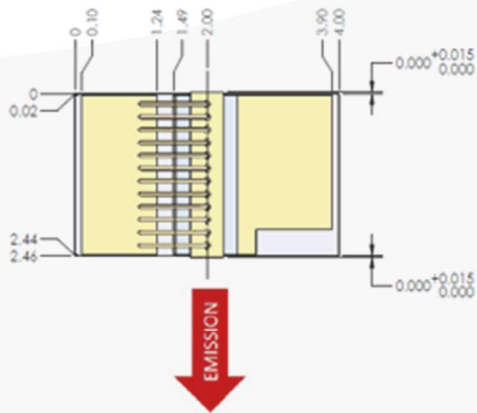
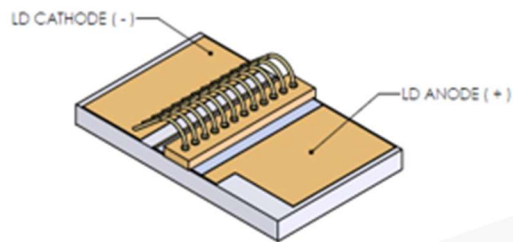
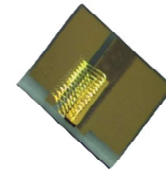

All statements, technical information and recommendations related to the product herein are based upon information believed to be reliable or accurate. The accuracy or completeness herein is not guaranteed, and no responsibility is assumed for any inaccuracies. The user assumes all risks and liability whatsoever in connection with the use of a product or its application. SemiNex Corporation reserves the right to change at any time without notice the design, specification, deduction, fit or form of its described herein, including withdrawal at any time of a product offered for sale herein. Users are encouraged to visit www.seminex.com for the latest data. SemiNex Corporation makes no representations that the products herein are free from any intellectual property claims of others. Please contact SemiNex for more information. 2016 SemiNex Corporation



SemiNex Corporation • 153 Andover Street, Suite 201, Danvers, MA 01923 • 978-326-7700 • sales@seminex.com